

Client: \_\_\_\_\_

Date: \_\_\_\_\_ / \_\_\_\_\_ / \_\_\_\_\_

Delivery desired date: \_\_\_\_\_ / \_\_\_\_\_ / \_\_\_\_\_

**01. INTRODUCTION**

**Chain Dimensions**

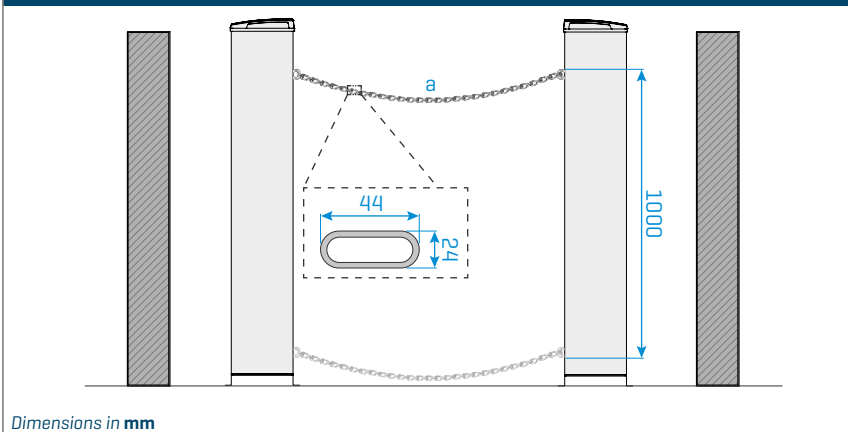

**Column Dimensions**

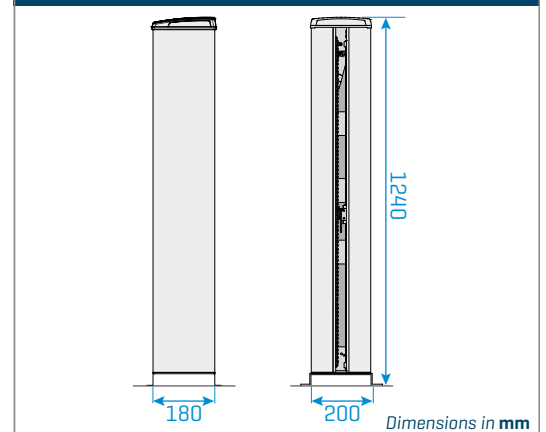

**Site Dimensions**

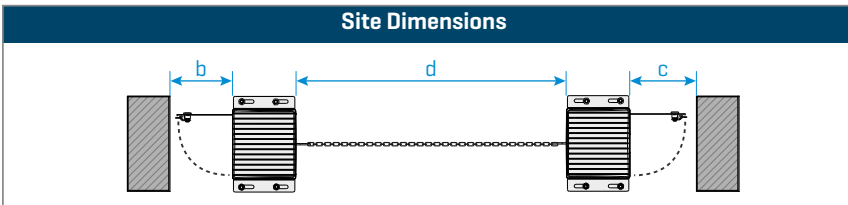

**Subtitle:**

- a - Chain Weight: maximum weight **20kg**;
- b - Free space on the door side: minimum **200mm**;
- c - Free space on the door side: minimum **200mm**;
- d - Passageway

**02. CHAIN**

**MATERIAL**

- Plastic (Standard)
- Iron

**LENGTH**

- 8 Meters (Standard)
  - Meters
- Please indicate if you require another length

**03. EXTRAS**

**CHLCCE** floor channel

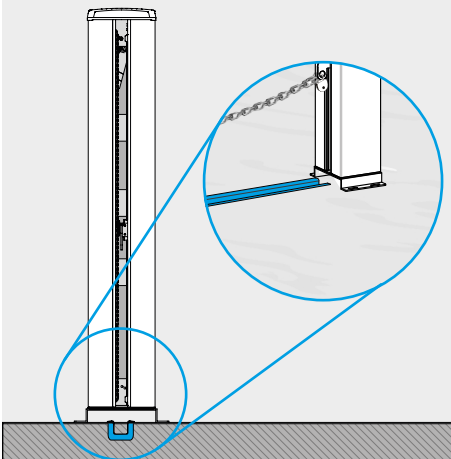

**CHLCCS** floor channel

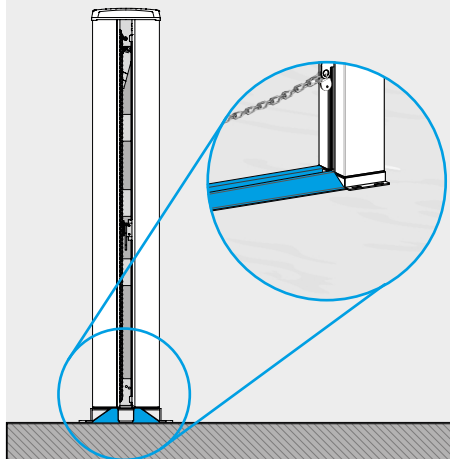

**2.2AH+CX50** Battery Kit

