

Client: _____

Date: ____ / ____ / ____

Desired supply date: ____ / ____ / ____

01. INSTALLATION LOCAL:

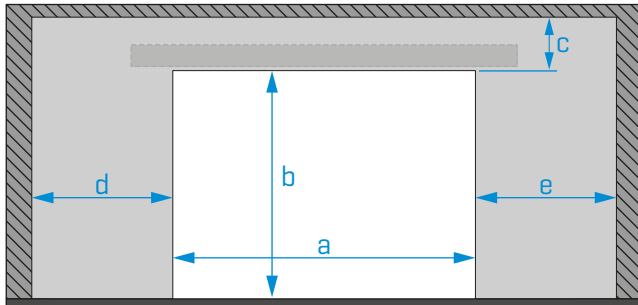

_____ [machine size]

Quantity _____



Local dimensions (mm):



Mandatory filling
← follow scheme



- [Clear passage width]
- [Clear passage height]
- [Lintel]
- [Left lateral]
- [Right lateral]

02. ADDITIONAL DEVICES:

[SELECT DESIRED OPTIONS WITH AN X AND PLACE QUANTITIES WHEN NECESSARY]



Complete with X
or with quantity

- M1601 - Radar
- MR27 - Radar with photocells
- MR30 - Radar with photocells
↳ Ceiling fixing plate
- RAP50 - Radar
- RAP100S - Radar with photocells
- FOT09S1A - Photocells
- MELE01 - Electric lock
- MR10 - Receiver
- FALK - Remote controls
- Glass [production form filling required]

X
 1, etc

SAFE

Textured finishing [standard]:

- Natural anodized
- White powder coating - RAL9110
- Black powder coating - RAL9005

Another workmanship:

Painting | RAL color _____

FRAME OR CLAMP

Textured finishing [standard]:

- Natural anodized
- White powder coating - RAL9110
- Black powder coating - RAL9005

Another workmanship:

Painting | RAL color _____

Other devices/accessories: _____

03. NUMBER OF LEAFS AND ORIENTATION:

[SELECT DESIRED OPTIONS WITH AN X]



1

- 1 mobile leaf
- Open to Left

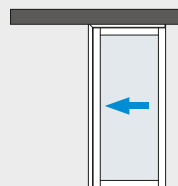

4

- 1 mobile leaf
- 1 fixed leaf
- Open to Left

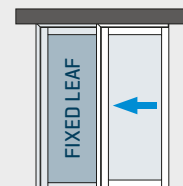

2

- 1 mobile leaf
- Open to Right

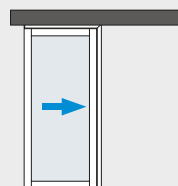

5

- 1 mobile leaf
- 1 fixed leaf
- Open to Right

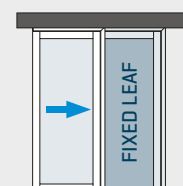

3

- 2 mobile leaves

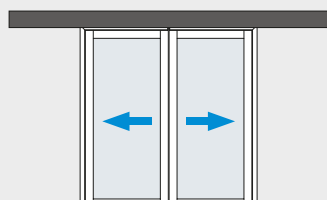

6

- 2 mobile leaves
- 2 fixed leaves

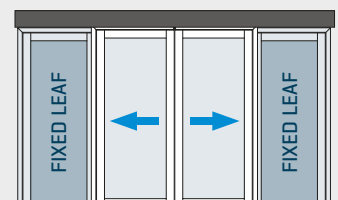

04. OPENING TYPE

[SELECT WITH X THE DESIRED OPTION]



1

STANDARD

Anti-panic leaves are turned towards the exterior with the safe installed on the interior side.

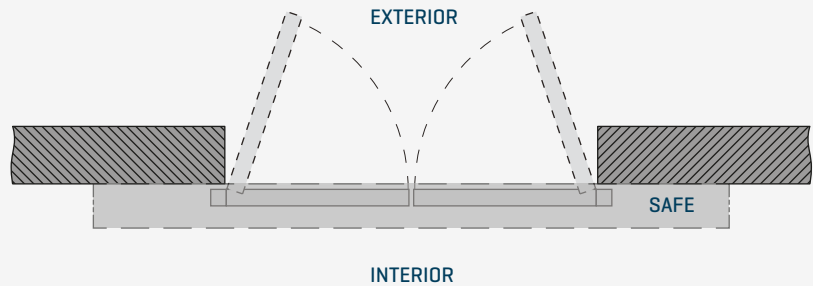

Note: The Anti-Panic system is only present in the mobile leaves, regardless of the existence of fixed leaves.

2

OPPOSITE

Anti-panic leaves are turned towards the exterior with the safe installed on the exterior side also.

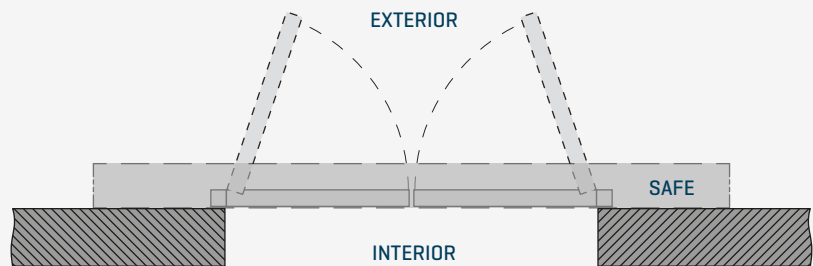

Note: The Anti-Panic system is only present in the mobile leaves, regardless of the existence of fixed leaves.

3

COMPLETE

Mobile and fixed anti-panic leaves are turned towards the exterior with the safe installed on the interior side.

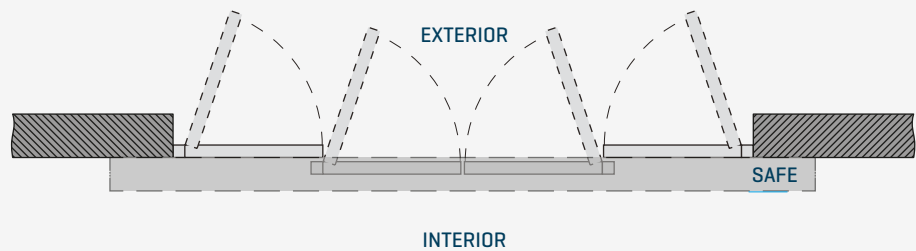

These types of opening are also used when using only 1 mobile leaf, or 1 mobile leaf and 1 fixed leaf.

OBSERVATIONS:

[IN THIS SPACE YOU SHOULD DESCRIBE EVERYTHING YOU FIND RELEVANT TO THE AUTOMATISM PRODUCTION]



05. APPLICATION MODE

[SELECT WITH X THE DESIRED OPTION]



Must only send this sheet if you want the glass leaves to be provided with the automatism.

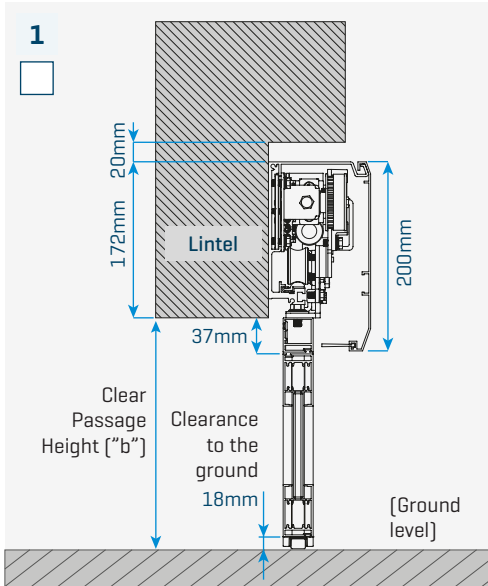

Semi-visible mode

Anti-Panic aluminum profile stays visible from the outside [192mm of minimum lintel]. Height of clear passage reduced in 28mm.

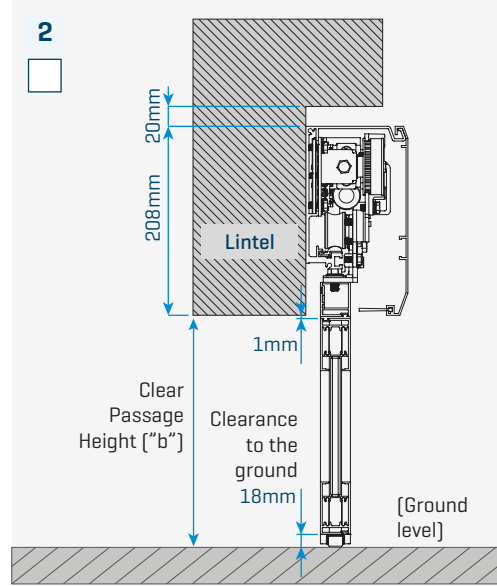

Invisible mode

Anti-Panic aluminum profile stays hidden behind the lintel [228mm of minimum lintel].

Warning: This option can not be used in case of selecting the "complete" opening type [previous page].

GLASS PRODUCTION



GLASS TYPE:

Example:

If you choose the "semi visible-mode" and have a clear passage height of 2000mm then the door leaf height must be 1945mm (2000 - 55).

GLASS DIMENSIONS FOR FRAME WORKMANSHIP

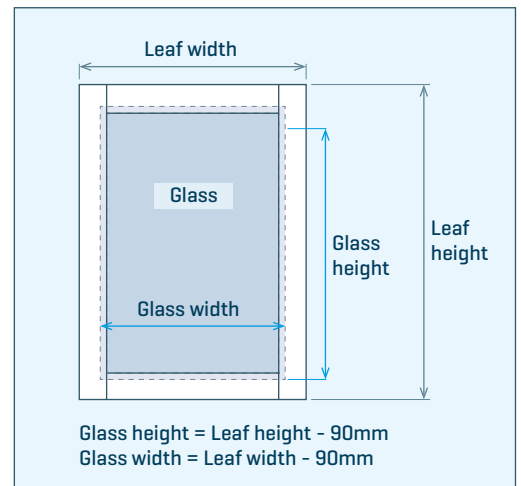

INVISIBLE MODE:

Height Glass Leaf = Clear Passage Height - 19mm

SEMI-VISIBLE MODE:

Height Glass Leaf = Clear Passage Height - 55mm

OBSERVATIONS:

[IN THIS SPACE YOU SHOULD DESCRIBE EVERYTHING YOU FIND RELEVANT TO THE AUTOMATISM PRODUCTION]