



TELICA

USER'S AND INSTALLER'S MANUAL









00. CONTENT

INDEX

01. SAFETY INSTRUCTIONS	1B
02. THE PACKAGE	
INSIDE THE PACKAGE	4A
03. AUTOMATION	
DIMENSIONS	4B
TECHNICAL SPECIFICATIONS	4B
04. INSTALLATION	
INTERIOR OPENING INSTALLATION DIMENSIONS	5A
EXTERNAL OPENING INSTALLATION DIMENSIONS	5B
EMERGENCY UNLOCK	6A
EXTERNAL UNLOCK	6A
SUPPORTS INSTALLATION	6B
AUTOMATISM INSTALLATION	7A
ARMS INSTALLATION	7A
MICROS ADJUSTMENT	7B
INSTALLATION MAP	8
05. MOTOR CONNECTIONS	
230V MOTOR	9A
24V MOTOR	9A
06. COMPONENTS TEST	
230V MOTOR	9B
24V MOTOR	10A
07. MAINTENANCE	
MAINTENANCE	10B
08. TROUBLESHOOTING	
INSTRUCTIONS FOR FINAL CONSUMERS	11A
INSTRUCTIONS FOR SPECIALIZED INSTALLERS	11B

01. SAFETY INSTRUCTIONS

	This product is certified in accordance with European Community (EC) safety standards.
	This product complies with Directive 2011/65/EU of the European Parliament and of the Council, of 8 June 2011, on the restriction of the use of certain hazardous substances in electrical and electronic equipment and with Delegated Directive (EU) 2015/863 from Commission.
	(Applicable in countries with recycling systems). This marking on the product or literature indicates that the product and electronic accessories (eg. Charger, USB cable, electronic material, controls, etc.) should not be disposed of as other household waste at the end of its useful life. To avoid possible harm to the environment or human health resulting from the uncontrolled disposal of waste, separate these items from other types of waste and recycle them responsibly to promote the sustainable reuse of material resources. Home users should contact the dealer where they purchased this product or the National Environment Agency for details on where and how they can take these items for environmentally safe recycling. Business users should contact their vendor and check the terms and conditions of the purchase agreement. This product and its electronic accessories should not be mixed with other commercial waste.
	This marking indicates that batteries should not be discarded like other household waste at the end of their useful life. Batteries must be delivered to selective collection points for recycling.
	The different types of packaging (cardboard, plastic, etc.) must be subject to selective collection for recycling. Separate packaging and recycle it responsibly.
	This marking indicates that the product and electronic accessories (eg. charger, USB cable, electronic material, controls, etc.) are susceptible to electric shock by direct or indirect contact with electricity. Be cautious when handling the product and observe all safety procedures in this manual.

01. SAFETY INSTRUCTIONS

GENERAL WARNINGS

- This manual contains very important safety and usage information. Read all instructions carefully before beginning the installation/usage procedures and keep this manual in a safe place that it can be consulted whenever necessary.
- This product is intended for use only as described in this manual. Any other enforcement or operation that is not mentioned is expressly prohibited, as it may damage the product and put people at risk causing serious injuries.
- This manual is intended firstly for specialized technicians, and does not invalidate the user's responsibility to read the "User Norms" section in order to ensure the correct functioning of the product.
- The installation and repair of this product may be done by qualified and specialized technicians, to assure every procedure are carried out in accordance with applicable rules and norms. Nonprofessional and inexperienced users are expressly prohibited of taking any action, unless explicitly requested by specialized technicians to do so.
- Installations must be frequently inspected for unbalance and the wear signals of the cables, springs, hinges, wheels, supports and other mechanical assembly parts.
- Do not use the product if it is necessary repair or adjustment is required.
- When performing maintenance, cleaning and replacement of parts, the product must be disconnected from power supply. Also including any operation that requires opening the product cover.
- The use, cleaning and maintenance of this product may be carried out by any persons aged eight years old and over and persons whose physical, sensorial or mental capacities are lower, or by persons without any knowledge of the product, provided that these are supervision and instructions given by persons with experienced in terms of usage of the product in a safe manner and who understands the risks and dangers involved.

- Children shouldn't play with the product or opening devices to avoid the motorized door or gate from being triggered involuntarily.
- If the power cable is damaged, it must be replaced by the manufacturer, after-sales service or similarly qualified personnel to avoid danger.
- The device must be disconnected from the electrical network when removing the battery.
- Ensure that blocking is avoided between the actuated part and its fixed parts due to the opening movement of the actuated part.

WARNINGS FOR TECHNICIANS

- Before beginning the installation procedures, make sure that you have all the devices and materials necessary to complete the installation of the product.
- You should note your Protection Index (IP) and operating temperature to ensure that is suitable for the installation site.
- Provide the manual of the product to the user and let them know how to handle it in an emergency.
- If the automatism is installed on a gate with a pedestrian door, a door locking mechanism must be installed while the gate is in motion.
- Do not install the product "upside down" or supported by elements do not support its weight. If necessary, add brackets at strategic points to ensure the safety of the automatism.
- Do not install the product in explosive site.
- Safety devices must protect the possible crushing, cutting, transport and danger areas of the motorized door or gate.
- Verify that the elements to be automated (gates, door, windows, blinds, etc.) are in perfect function, aligned and level. Also verify if the necessary mechanical stops are in the appropriate places.
- The control board must be installed on a safe place of any fluid (rain, moisture, etc.), dust and pests.
- You must route the various electrical cables through protective tubes, to protect them against mechanical exertions, essentially on

01. SAFETY INSTRUCTIONS

the power supply cable. Please note that all the cables must enter the control board from the bottom.

- If the automatism is to be installed at a height of more than 2,5m from the ground or other level of access, the minimum safety and health requirements for the use of work equipment workers at the work of Directive 2009/104/CE of European Parliament and of the Council of 16 September 2009.
- Attach the permanent label for the manual release as close as possible to the release mechanism.
- Disconnect means, such as a switch or circuit breaker on the electrical panel, must be provided on the product's fixed power supply leads in accordance with the installation rules.
- If the product to be installed requires power supply of 230Vac or 110Vac, ensure that connection is to an electrical panel with ground connection.
- The product is only powered by low voltage safety with control board (only at 24V motors).
- Parts/products weighing more than 20 kg must be handled with special care due to the risk of injury. It is recommended to use suitable auxiliary systems for moving or lifting heavy objects.
- Pay special attention to the danger of falling objects or uncontrolled movement of doors/gates during the installation or operation of this product.

WARNINGS FOR USERS

- Keep this manual in a safe place to be consulted whenever necessary.
- If the product has contact with fluids without being prepared, it must immediately disconnect from the power supply to avoid short circuits, and consult a specialized technician.
- Ensure that technician has provided you the product manual and informed you how to handle the product in an emergency.
- If the system requires any repair or modification, unlock the automatism, turn off the power and do not use it until all safety

conditions have been met.

- In the event of tripping of circuits breakers or fuse failure, locate the malfunction and solve it before resetting the circuit breaker or replacing the fuse. If the malfunction is not repairable by consult this manual, contact a technician.
- Keep the operation area of the motorized gate free while the gate in in motion, and do not create strength to the gate movement.
- Do not perform any operation on mechanical elements or hinges if the product is in motion.

RESPONSABILITY

- Supplier disclaims any liability if:
 - Product failure or deformation result from improper installation use or maintenance!
 - Safety norms are not followed in the installation, use and maintenance of the product.
 - Instructions in this manual are not followed.
 - Damaged is caused by unauthorized modifications
 - In these cases, the warranty is voided.

MOTORLINE ELECTROCELOS SA.

Travessa do Sobreiro, nº29
4755-474 Rio Côvo (Santa Eugénia)
Barcelos, Portugal

SYMBOLS LEGEND:



• Important safety notices



• Useful information



• Programming information



• Potentiometer information



• Connectors information



• Buttons information

02. THE PACKAGE

INSIDE THE PACKAGE

Components on the 2 motor's package:

- 01 • 02 articulated motors
- 02a • 01 articulated right arm
- 02b • 01 articulated left arm
- 03 • 02 4 channels remote controls
- 04 • 02 frontal supports
- 05 • 02 motor supports
- 06 • 02 unlock keys
- 07 • 01 photocells set
- 08 • 01 user manual

Components on the 1 motor's package:

- 01 • 01 articulated motor
- 02a • 01 articulated right/left arm
- 03 • 02 4 channels remote controls
- 04 • 01 frontal support
- 05 • 01 motor's support
- 06 • 01 unlock key
- 07 • 01 photocells set
- 08 • 01 user manual

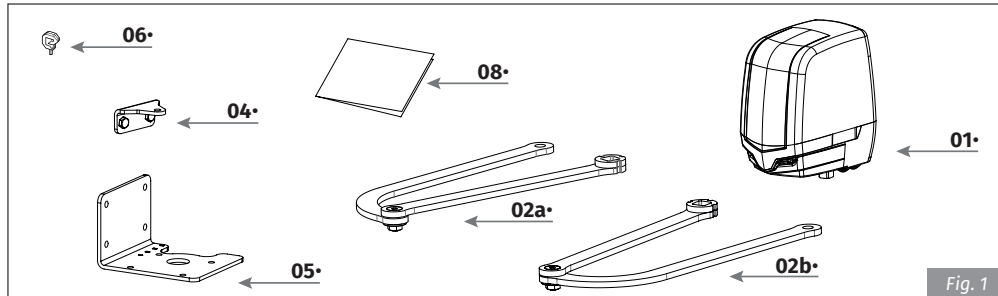

Kit components:



Kit package:

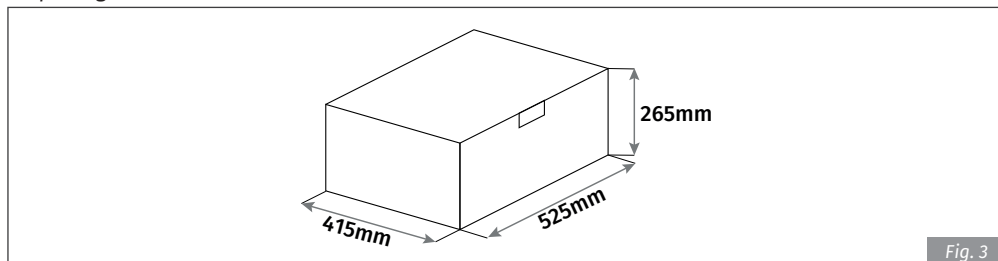

03. AUTOMATION

DIMENSIONS

The dimensions of the **TELICA** automation are the following:

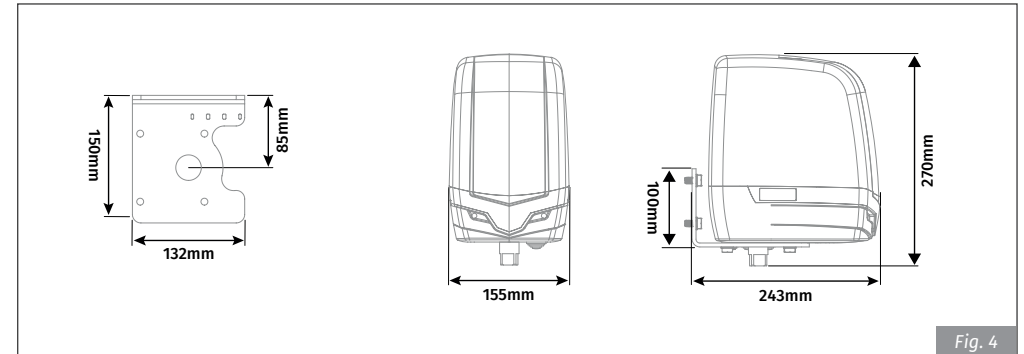

TECHNICAL SPECIFICATIONS

	24V	230V
• Power supply	24Vdc	230Vac 50/60Hz
• Power	220W	380W
• Force	200Nm	
• Working frequency	55%	30%
• Capacitor	-	12,5 µF
• Protection class	IP54	
• Noise	LpA <= 50dB (A)	
• Operating temperature	-25°C to 55°C	
• Maximum speed	20mm/s	
• Maximum width per leaf <i>without electric lock</i>	2500mm	
• Maximum width per leaf <i>with electric lock</i>	4000mm	

04. INSTALLATION

INTERIOR OPENING INSTALLATION DIMENSIONS



When installing the automation, it is mandatory to respect the dimensions x and y, indicated in the tables. Within this area, it is possible to identify the maximum opening angle that the gate reaches in these dimensions. It is very important that these dimensions are respected! Only this way can be assured the correct functioning and durability of the automation!

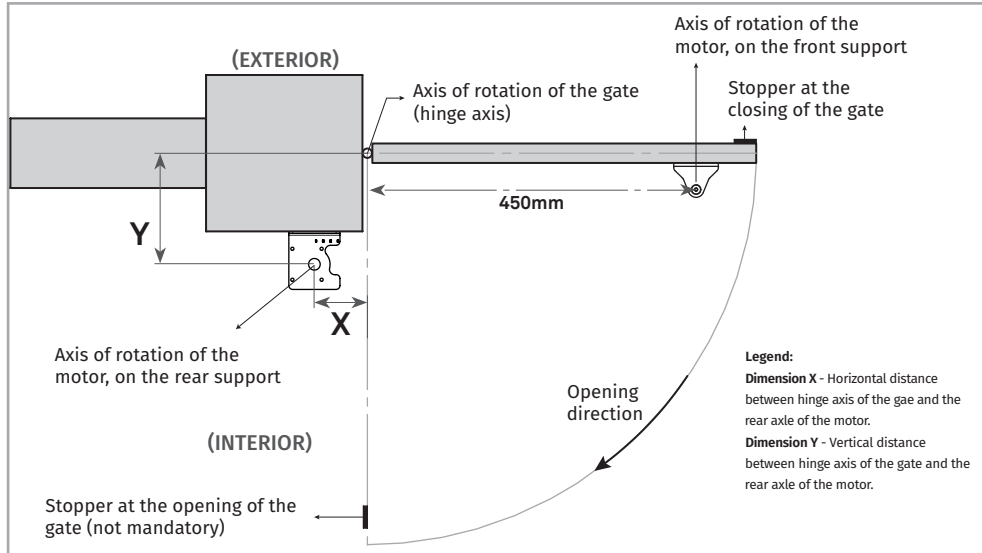

Dimensions Y	Dimensions X										
	260	240	220	200	180	160	140	120	100	80	60
60	-	-	-	-	-	-	-	-	-	-	-
80	-	-	-	-	-	-	-	-	-	-	-
100	-	-	-	-	-	-	-	-	-	-	-
120	-	-	-	-	-	-	-	-	-	-	-
140	-	-	-	-	-	-	-	-	-	-	-
160	-	-	-	-	-	-	-	-	-	-	-
180	-	-	-	-	-	-	-	-	-	-	-
200	-	-	-	-	-	-	-	-	-	-	-
220	-	-	-	-	-	-	-	-	-	-	-
240	-	-	-	-	-	-	-	-	-	-	-
260	-	-	-	-	-	-	-	-	-	-	-
280	-	-	-	-	-	-	-	-	-	-	-
300	-	-	-	-	-	-	-	-	-	-	-
320	-	-	-	-	-	-	-	-	-	-	-
340	-	-	-	-	-	-	-	-	-	-	-
360	-	-	-	-	-	-	-	-	-	-	-
380	-	-	-	-	-	-	-	-	-	-	-

■ Dimensions suitable for installation
 - Dimensions not allowed

04. INSTALLATION

EXTERNAL OPENING INSTALLATION DIMENSIONS

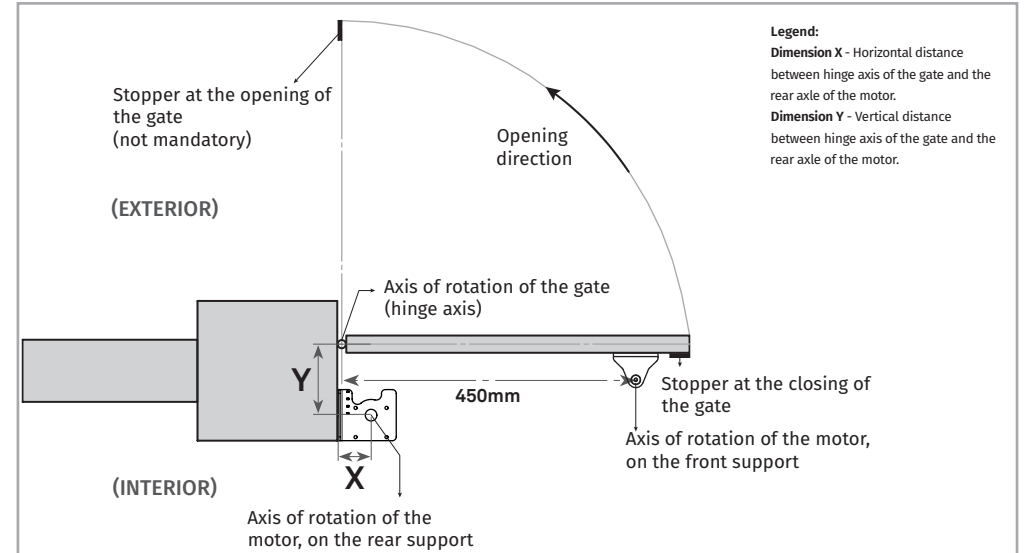

Legend:
 Dimension X - Horizontal distance between hinge axis of the gate and the rear axle of the motor.
 Dimension Y - Vertical distance between hinge axis of the gate and the rear axle of the motor.

Dimensions Y	Dimensions X															
	360	340	320	300	280	260	240	220	200	180	160	140	120	100	80	60
80	-	-	-	-	-	-	-	-	-	-	-	-	-	-	-	-
100	-	-	-	-	-	-	-	-	-	-	-	-	-	-	-	-
120	-	-	-	-	-	-	-	-	-	-	-	-	-	-	-	-
140	-	-	-	-	-	-	-	-	-	-	-	-	-	-	-	-
160	-	-	-	-	-	-	-	-	-	-	-	-	-	-	-	-
180	-	-	-	-	-	-	-	-	-	-	-	-	-	-	-	-
200	-	-	-	-	-	-	-	-	-	-	-	-	-	-	-	-
220	-	-	-	-	-	-	-	-	-	-	-	-	-	-	-	-
240	-	-	-	-	-	-	-	-	-	-	-	-	-	-	-	-
260	-	-	-	-	-	-	-	-	-	-	-	-	-	-	-	-

04. INSTALLATION

EMERGENCY UNLOCK



The emergency unlock should only be used in case of emergency, electrical failure or malfunction.

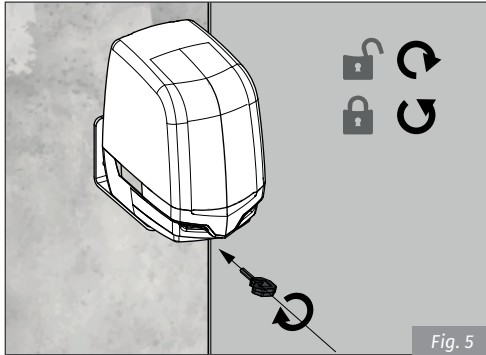

To unlock...
insert the unlock key into the automation front hole and turn it on clockwise 4-5 times until you feel a limit.

To lock...
Turn the key in the opposite direction until you feel an obstacle.

Fig. 5

EXTERNAL UNLOCK



The kit exemplified below is not included in the **TELICA Kit**.

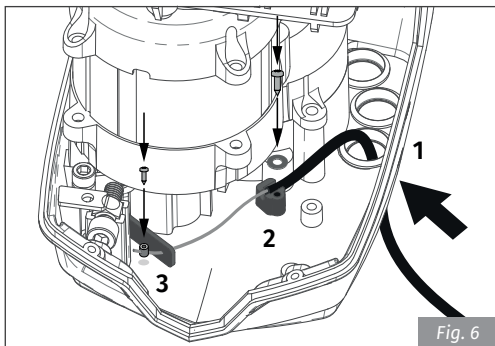

Fig. 6

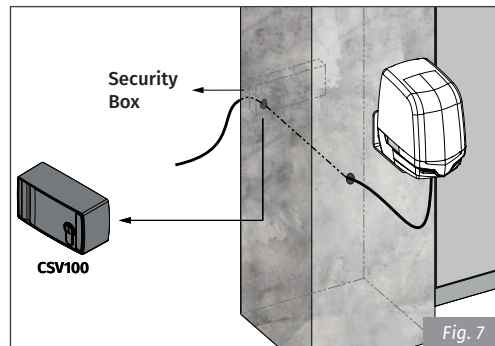

Fig. 7

- 1 • Pass the cable into the **TELICA** through the cable gland.
- 2 • Place the cable sleeve in the indicated location and fix it with a washer and a screw.
- 3 • Pass the steel cable through the hole in the trigger and fix it with an end-fixing. Cut the excess.

The cable can then be connected to a security box as in **fig. 7** to allow external unlocking.

04. INSTALLATION

SUPPORTS INSTALLATION

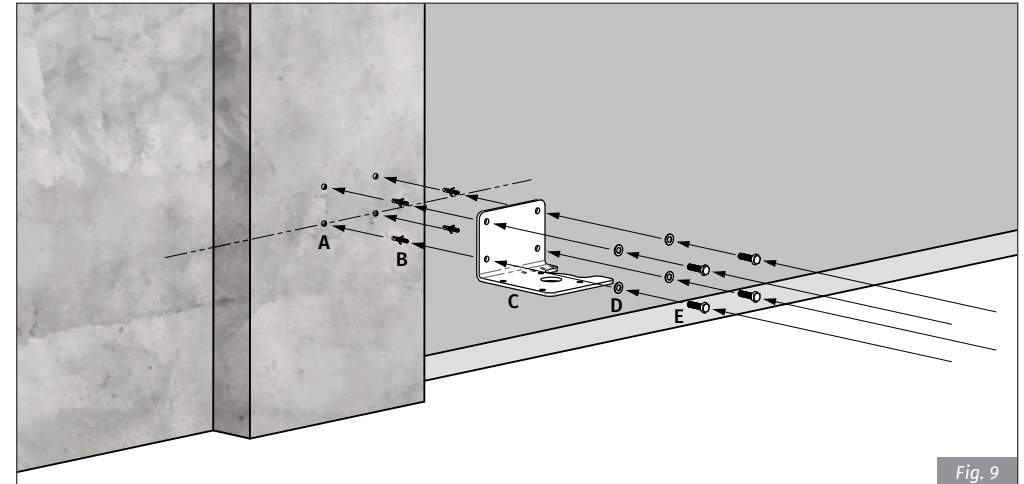

Fig. 9

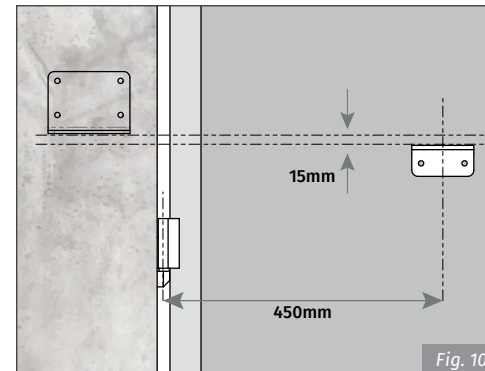

Fig. 10

- 1 • Drill holes for M8 screw anchors.
• You must use appropriate fixings for the type of surface where the automation will be installed.
- 2 • Place the anchors in the holes, press the plate against the wall and fix it with the appropriate screws.
- 3 • Attach the front support to the gate leaf, following the dimensions of **Fig. 10**. • 450mm from the gate hinge and 15mm below the motor support.



Use M8 screws for fixing the supports.

04. INSTALLATION

AUTOMATISM INSTALLATION

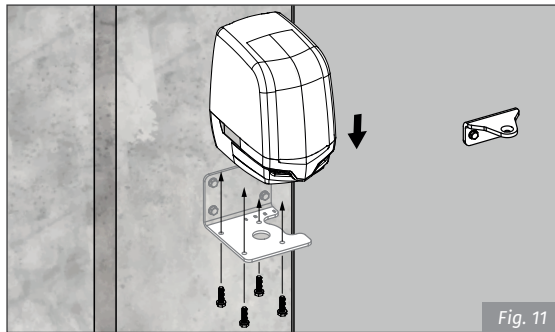

- 1 • Place the motor on the support plate and fix it with supplied M8 screws.

ARMS INSTALLATION

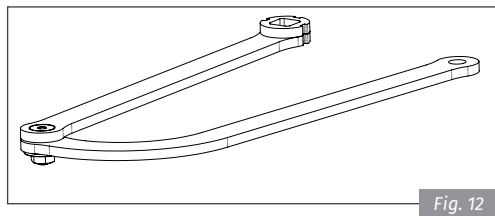

- The arms are supplied already assembled.
• If you install only one motor and the arm is not in the correct position, you can easily change the direction following the indications in the picture Fig. 13.

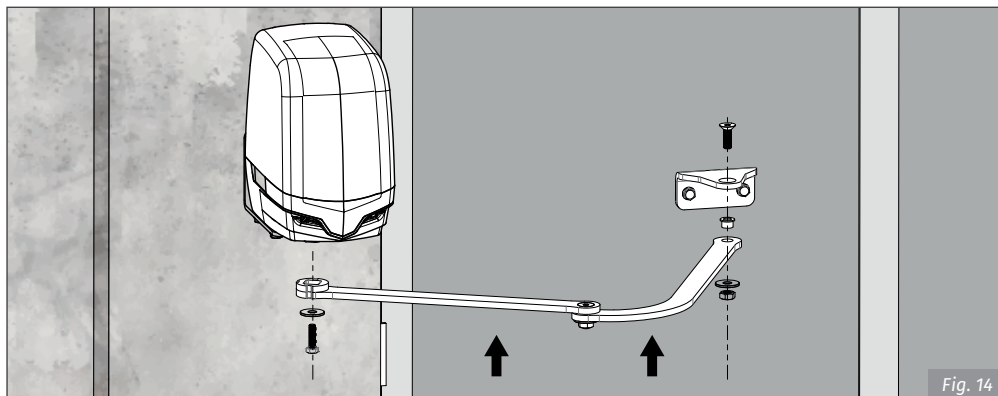
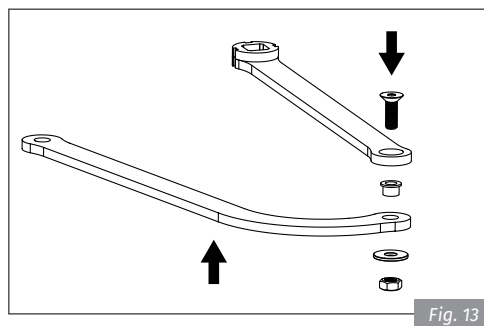

- 1 • Mount the square hole in the motor's output shaft, and tighten with provided washer and M10x20 screw. 2 • Place the other end of the arm under the gate support, and fix with screw, bushing, washer, and nut.

04. INSTALLATION

MICROS ADJUSTMENT

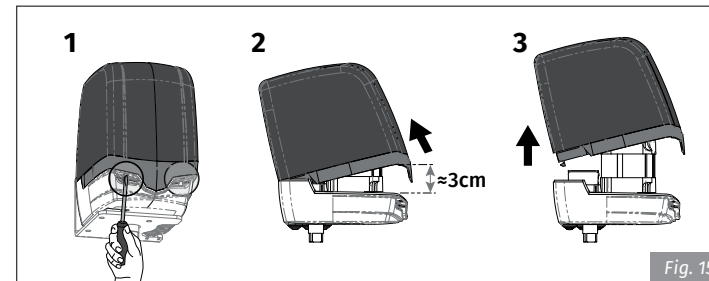

- Remove the automation's cover. To do this, loosen the two front screws, slightly tilt the cover back and pull up.

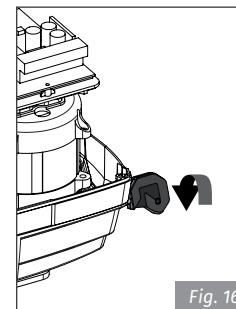

- 1 • Unlock the automation and open the gate leaf to the desired position.

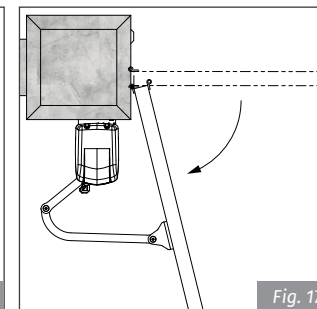

- 2 • Loosen (A) the opening ring screw, and turn it (B) until you hear a *click* of the micro switch.

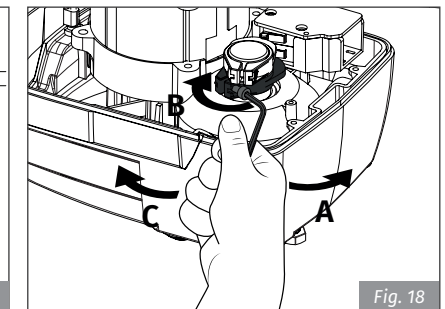

- 3 • Tighten the screw (C) of the ring to lock it in this position.

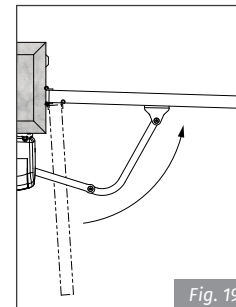

- 4 • Close the gate leaf, loosen (A) and turn (B) the closing ring until it makes a *click* into the corresponding micro. Retighten (C) the ring screw.

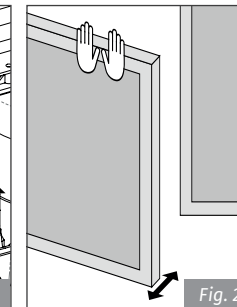
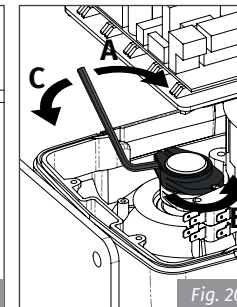

- 5 • Manually test the opening and closing of the gate to ensure that the micro switches are activated in the correct point. 6 • When the micros are tuned, re-lock the automation.

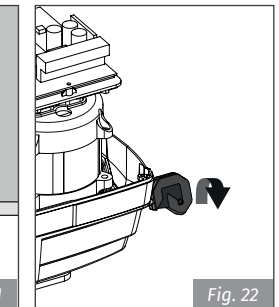

After the installation is complete, make all the electrical connections and replace the cover.

04. INSTALLATION

INSTALLATION MAP

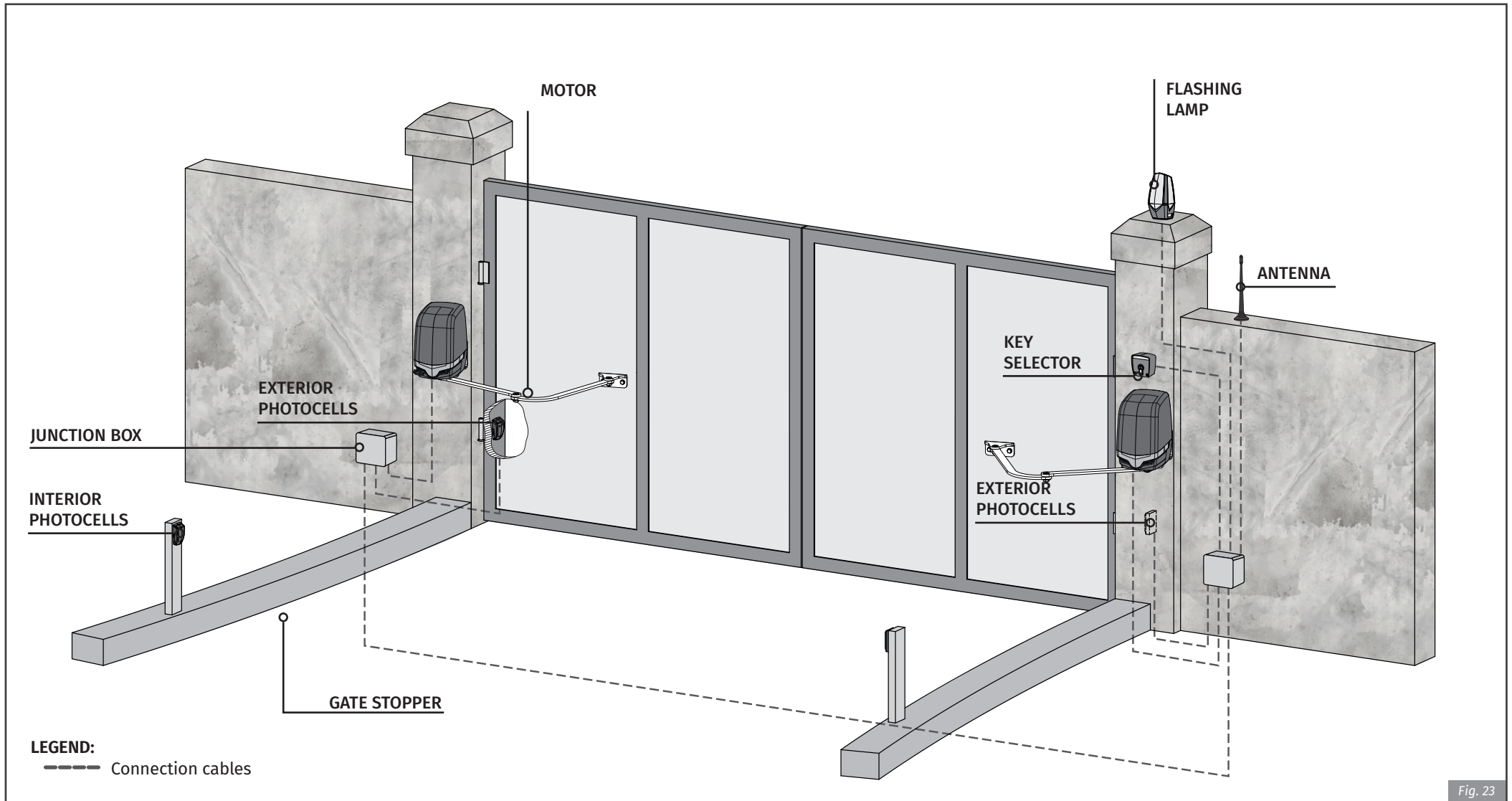

It is important to use stoppers at the opening and closing of the gate. If not respected, components of the automation may suffer efforts for which they were not prepared, and as a result will be damaged.



It is important to use junction boxes for connections between motors, components and control board. All cables must enter and exit on the bottom of the junction and control board boxes.

05. CONNECTION SCHEME

230V MOTOR

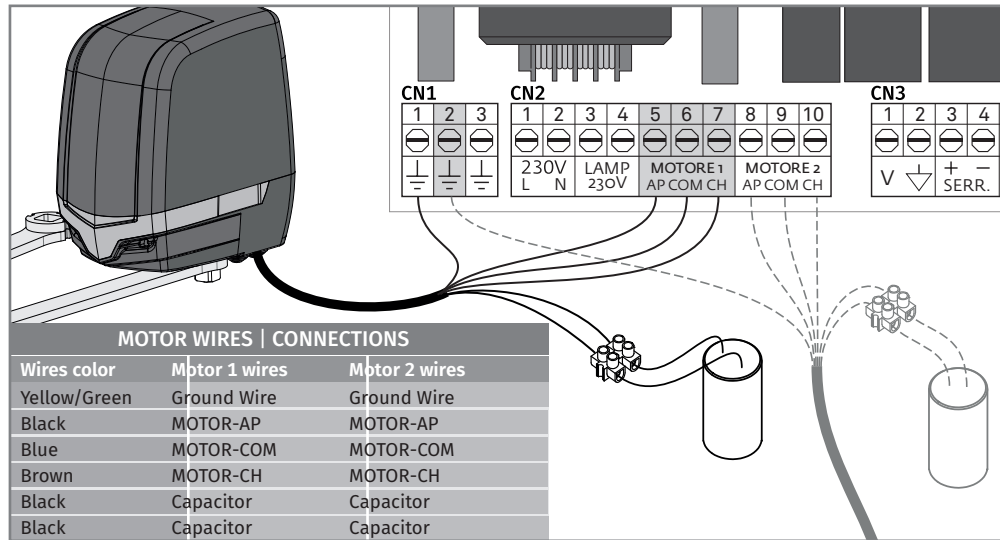

Connections should be made as shown above, connecting the 6 motor wires to the appropriate inputs of the control board and capacitor.

NOTE: The white motor wires are connected directly to the capacitor wires!



- These connections correspond to an **installation with an opening to the interior**. If the automation is installed with an opening towards the **outside** of the gate, you **must swap the AP wire with the CH wire** on the motor 1 and 2.
- If the **motors work towards the opposite direction**, swap AP with CH.

24V MOTOR

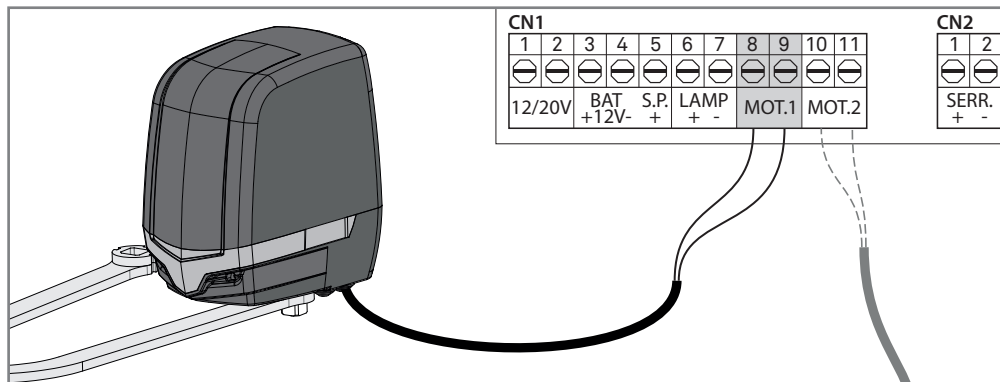

06. COMPONENTS TEST

230V MOTOR

To detect if the malfunction is on the control board or on the motor is, sometimes, necessary to perform tests with direct connection to a 230Vac power supply.

For this, it is necessary to intercalate a capacitor on the connection in order to the automatism to work (check the type of capacitor to be used in the product manual).

The diagram below, shows how to make that connection and how to intercalate the different components wires.



NOTES:

- To perform the tests, there is no need to remove the automatism from the place it is installed, because in this way, it is possible to understand if the automatism can function properly connected directly to the power.
- You should use a new capacitor during this test to ensure that the problem is not with the capacitor.

1 • Connect the power wires to the terminal, as shown below.

2 • Connect the automatism wires in the terminal, intercalating a capacitor in the opening and closing wires.

3 • Once these connections are completed, connect to a 230Vac power plug, depending on the motor / control board in test.

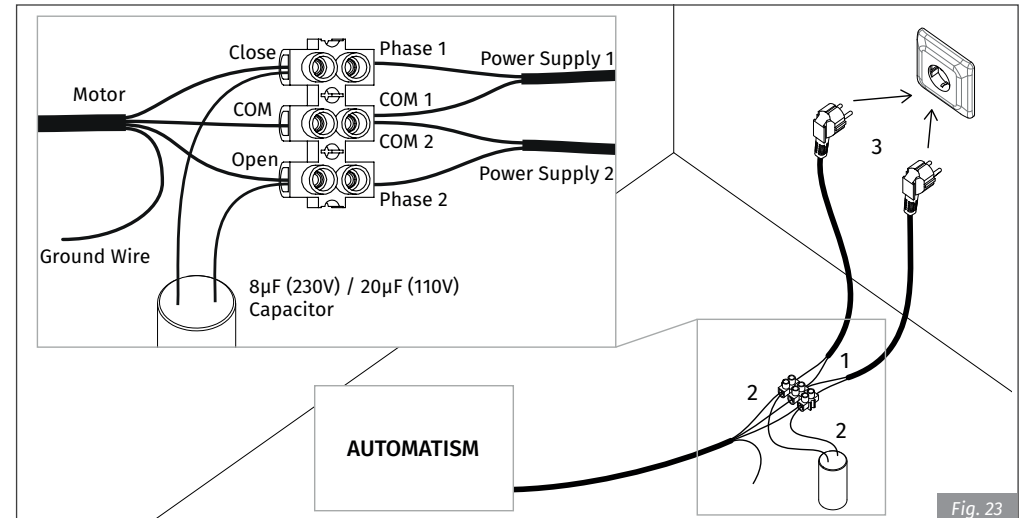

Fig. 23



All tests must be performed by specialized technicians due to serious danger associated with the misuse of electrical systems!

06. COMPONENTS TEST

24V MOTOR

To detect which are the components with problems in a **24Vdc TELICA** automatism installation, it's sometimes necessary to run a test directly to a external power supply (24Vdc battery). The diagram below shows how to make this connection.



NOTES:

- To make these tests it isn't necessary to remove it from the location where it is installed, because in this way, you can understand if the automation connected directly to the external battery is able to work correctly.
- Once you connect the wires to a battery 24V, the motor must work for one direction. To test the opposite movement, change the position of the wires connected to the battery.

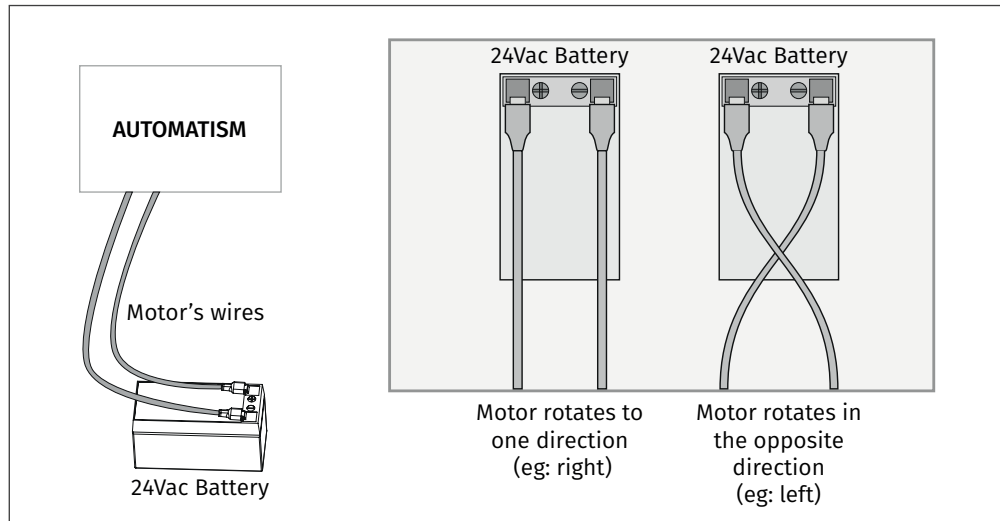

All tests must be performed by specialized technicians due to serious danger associated with the bad use of electrical systems!

07. MAINTENANCE

MAINTENANCE

• CHECK SUPPORT PLATES

Make sure that supports remain well fixed on the pillars and gate to ensure proper functioning of the equipment.

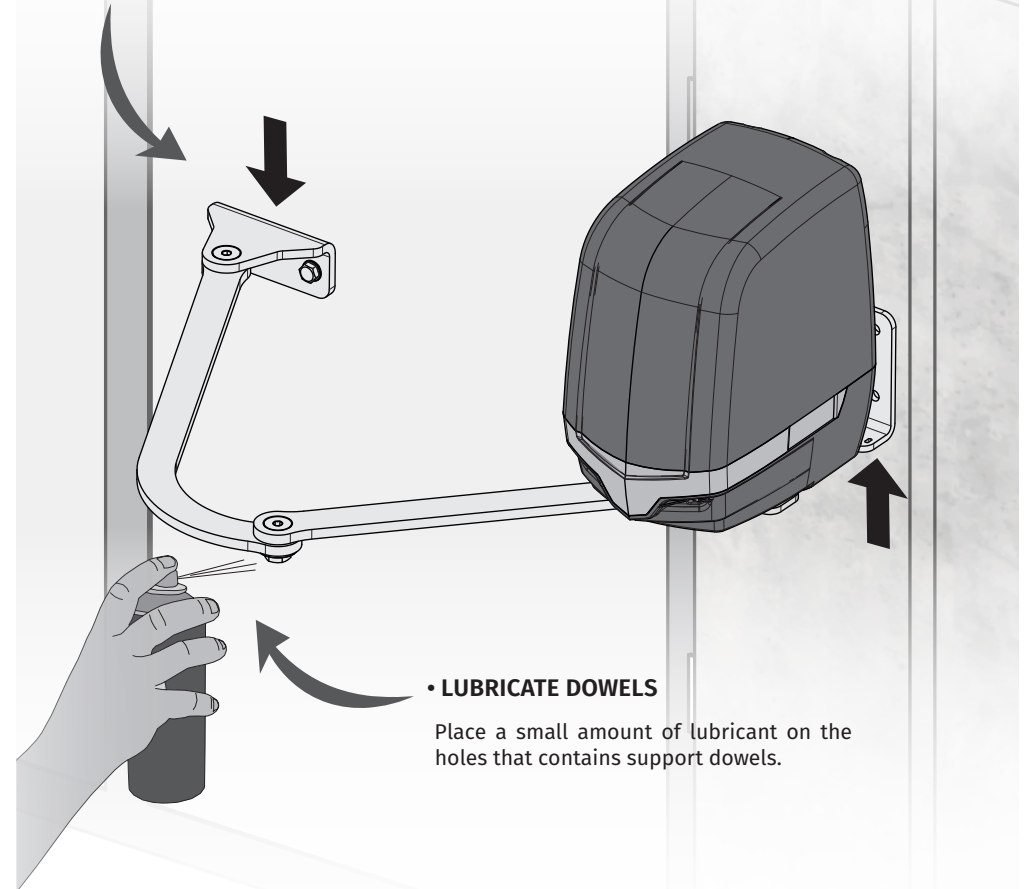

These maintenance measures must be applied every year in order to insure proper functioning of the automation.

08. TROUBLESHOOTING

INSTRUCTIONS FOR FINAL CONSUMERS

INSTRUCTIONS FOR SPECIALIZED INSTALLERS

Anomaly	Procedure	Behavior	Procedure II	Discovering the origin of the problem
• Motor doesn't work	• Check that the 230Vac/24Vdc power supply is connected to the automation and if it is working properly.	• Still not working	• Consult a qualified MOTORLINE technician.	<ol style="list-style-type: none"> 1 • Open control board and check if it has 230Vac/24Vdc power supply; 2 • Check input fuses; 3 • Disconnect motor from control board and test it by connecting directly to power supply in order to find out if it has problems (see page 9B) 4 • If the motor work, the problem is on the control board. Pull it out and send it to our MOTORLINE technical services for diagnosis; 5 • If the motor doesn't work, remove it from installation site and send to our MOTORLINE technical services for diagnosis.
• Motor doesn't move but makes noise	• Unlock motor and move gate by hand to check for mechanical problems on the gate.	Encountered problems?	• Consult an experienced gate expert.	1 • Check all motion axis and associated motion systems related with gate and automation (dowels, hinges, etc.) to find out what is the problem.
		• Gate moves easily?	• Consult a qualified MOTORLINE technician.	<ol style="list-style-type: none"> 1 • Disconnect motor from control board and test it by connecting directly to power supply in order to find out if it has problems (see page 9B) 2 • If the motor work, the problem is on the control board. Pull it out and send it to our MOTORLINE technical services for diagnosis; 3 • If the motor doesn't work, remove it from installation site and send to our MOTORLINE technical services for diagnosis.
• Motor opens but doesn't close	• Unlock motor and move gate by hand to closed position. Lock motor(s) again and turn off power supply for 5 seconds. Reconnect it and send order to open gate using remote control.	• Gate opened but didn't close again.	<ol style="list-style-type: none"> 1 • Check if there is any obstacle in front of the photocells; 2 • Check if any of the control devices (key selector, push button, video intercom, etc.) of the gate are enough and sending permanent signal to control board; 3 • Consult a qualified MOTORLINE technician. 	<p>All MOTORLINE control boards have LEDs that easily allow to conclude which devices are with anomalies. All safety devices LEDs (DS) in normal situations remain On. All "START" circuits LEDs in normal situations remain Off.</p> <p>If LEDs devices are not all On, there is some security systems malfunction (photocells, safety edges), etc. If "START" circuits LEDs are turn On, there is a control device sending permanent signal.</p> <p>A) SECURITY SYSTEMS:</p> <ol style="list-style-type: none"> 1 • Close with a shunt all safety systems on the control board (check manual of the control board). If the automated system starts working normally check which device is problematic. 2 • Remove one shunt at a time until you find the malfunction device . 3 • Replace it for a functional device and check if the automation works correctly with all the other devices. If you find another one defective, follow the same steps until you find all the problems. <p>B) START SYSTEMS:</p> <ol style="list-style-type: none"> 1 • Disconnect all wires connected to the START connector (PUL and PED). 2 • If the LED turned Off, try reconnecting one device at a time until you find the defective device. <p>NOTE: If the procedures described in sections A) and B) don't result, remove control board and send to our technical services for diagnosis.</p>
• Motor doesn't make complete route	• Unlock motor and move gate by hand to check for mechanical problems on the gate.	Encountered problems?	• Consult an experienced gate expert	1 • Check all motion axis and associated motion systems related with gate and automation (dowels, hinges, etc.) to find out what is the problem.
		• Gate moves easily?	• Consult a qualified MOTORLINE technician.	<ol style="list-style-type: none"> 1 • Check if the micros of the limit switches are adjusted for the required course. 2 • Disconnect motor from control board and test it by connecting directly to power supply in order to find out if it has problems (see page 9B). 3 • If the motor doesn't work, remove it from installation site and send to our MOTORLINE technical services for diagnosis. 4 • If motors work well and move gate at full force during the entire course, the problem is in the control board. Set force using trimmer on the board. Make a new working time programming , giving enough time for opening and closing with appropriate force (see manual of the control board). 5 • If this does not work, remove the control board and send it to MOTORLINE services for diagnosis. <p>NOTE: Setting force of the control board should be enough to open and close the gate without stopping, but should stop with a little effort from a person. In case of safety systems failure, the gate can never cause physical damage to obstacles (vehicles, people, etc.).</p>