

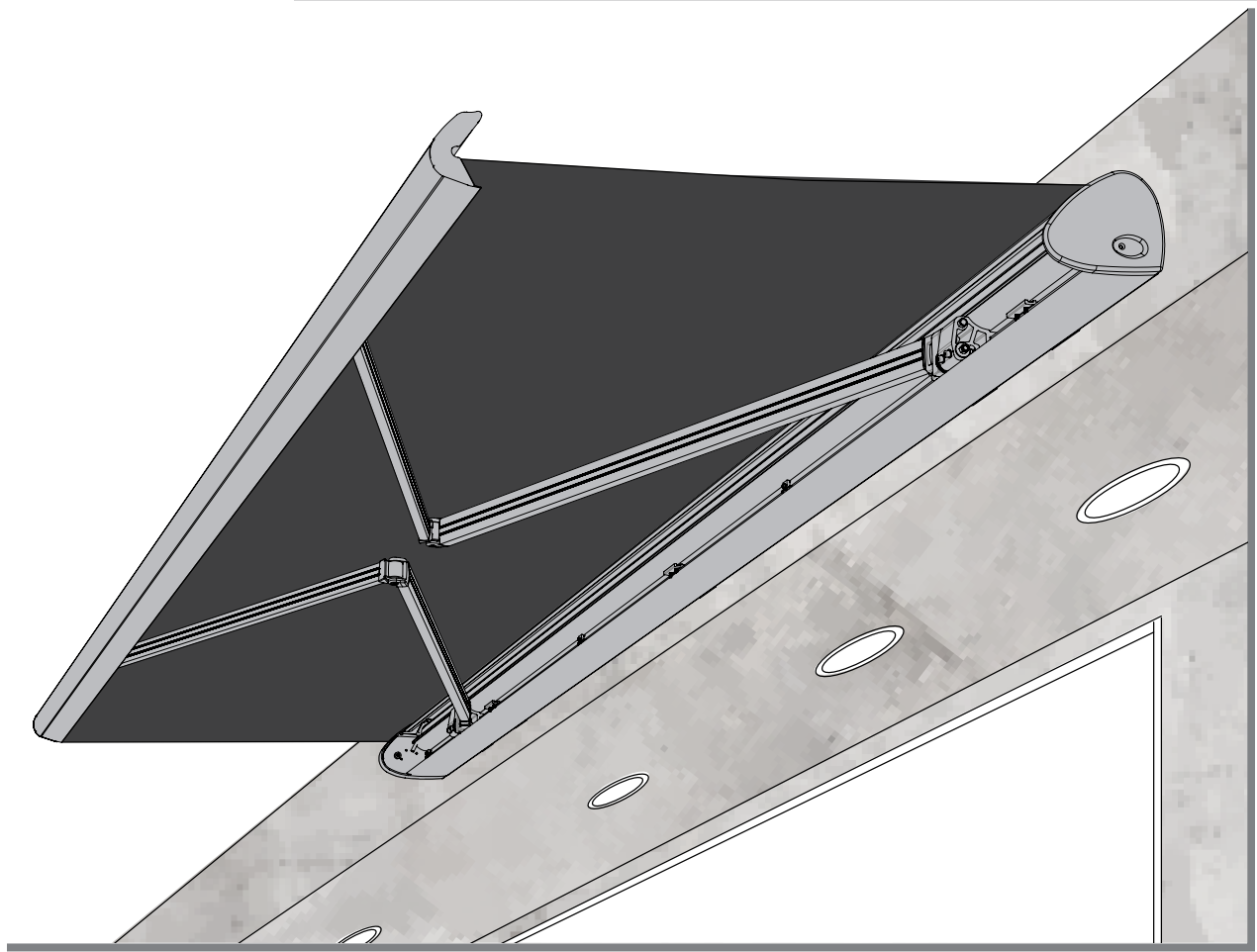

COFRE 600

INSTALLER AND USER'S MANUAL







00. CONTENT

INDEX

01. SAFETY INSTRUCTIONS	1B
02. AWNING	
COFRE 600	4A
TECHNICAL CHARACTERISTICS	4B
03. INSTALLATION	
HOLDERS INSTALLATION MEASUREMENTS	5A
PRE-INSTALLATION	5B
FIXING ON THE WALL	6A
FIXING ON THE CEILING	7A
04. REGULATION	
SETTING THE ARM JOINT	8A
ADJUSTING THE AWNING TILT	8B
ADJUSTING THE FRONT PROFILE	9A
MANUAL UNLOCKING	9B
ENDS OF COURSE	10A
05. TROUBLESHOOTING	
FINAL CONSUMERS AND SPECIALIZED TECHNICIANS INSTRUCTIONS	11A

01. SAFETY INSTRUCTIONS

	This product is certified in accordance with European Community (EC) safety standards.
RoHS	This product complies with Directive 2011/65/EU of the European Parliament and of the Council, of 8 June 2011, on the restriction of the use of certain hazardous substances in electrical and electronic equipment and with Delegated Directive (EU) 2015/863 from Commission.
	(Applicable in countries with recycling systems). This marking on the product or literature indicates that the product and electronic accessories (eg. Charger, USB cable, electronic material, controls, etc.) should not be disposed of as other household waste at the end of its useful life. To avoid possible harm to the environment or human health resulting from the uncontrolled disposal of waste, separate these items from other types of waste and recycle them responsibly to promote the sustainable reuse of material resources. Home users should contact the dealer where they purchased this product or the National Environment Agency for details on where and how they can take these items for environmentally safe recycling. Business users should contact their vendor and check the terms and conditions of the purchase agreement. This product and its electronic accessories should not be mixed with other commercial waste.
	This marking indicates that batteries should not be discarded like other household waste at the end of their useful life. Batteries must be delivered to selective collection points for recycling.
	The different types of packaging (cardboard, plastic, etc.) must be subject to selective collection for recycling. Separate packaging and recycle it responsibly.
	This marking indicates that the product and electronic accessories (eg. charger, USB cable, electronic material, controls, etc.) are susceptible to electric shock by direct or indirect contact with electricity. Be cautious when handling the product and observe all safety procedures in this manual.

01. SAFETY INSTRUCTIONS

GENERAL WARNINGS

- This manual contains very important safety and usage information. Read all instructions carefully before beginning the installation/usage procedures and keep this manual in a safe place that it can be consulted whenever necessary.
- This product is intended for use only as described in this manual. Any other enforcement or operation that is not mentioned is expressly prohibited, as it may damage the product and put people at risk causing serious injuries.
- This manual is intended firstly for specialized technicians, and does not invalidate the user's responsibility to read the "User Norms" section in order to ensure the correct functioning of the product.
- The installation and repair of this product may be done by qualified and specialized technicians, to assure every procedure are carried out in accordance with applicable rules and norms. Nonprofessional and inexperienced users are expressly prohibited of taking any action, unless explicitly requested by specialized technicians to do so.
- Installations must be frequently inspected for unbalance and the wear signals of the cables, springs, hinges, wheels, supports and other mechanical assembly parts.
- Do not use the product if it is necessary repair or adjustment is required.
- When performing maintenance, cleaning and replacement of parts, the product must be disconnected from power supply. Also including any operation that requires opening the product cover.
- The use, cleaning and maintenance of this product may be carried out by any persons aged eight years old and over and persons whose physical, sensorial or mental capacities are lower, or by persons without any knowledge of the product, provided that these are supervision and instructions given by persons with experienced in terms of usage of the product in a safe manner and who understands the risks and dangers involved.

- Children shouldn't play with the product or opening devices to avoid the motorized door or gate from being triggered involuntarily.
- If the power cable is damaged, it must be replaced by the manufacturer, after-sales service or similarly qualified personnel to avoid danger.
- The device must be disconnected from the electrical network when removing the battery.
- Ensure that blocking is avoided between the actuated part and its fixed parts due to the opening movement of the actuated part.

WARNINGS FOR TECHNICIANS

- Before beginning the installation procedures, make sure that you have all the devices and materials necessary to complete the installation of the product.
- You should note your Protection Index (IP) and operating temperature to ensure that is suitable for the installation site.
- Provide the manual of the product to the user and let them know how to handle it in an emergency.
- If the automatism is installed on a gate with a pedestrian door, a door locking mechanism must be installed while the gate is in motion.
- Do not install the product "upside down" or supported by elements do not support its weight. If necessary, add brackets at strategic points to ensure the safety of the automatism.
- Do not install the product in explosive site.
- Safety devices must protect the possible crushing, cutting, transport and danger areas of the motorized door or gate.
- Verify that the elements to be automated (gates, door, windows, blinds, etc.) are in perfect function, aligned and level. Also verify if the necessary mechanical stops are in the appropriate places.
- The control board must be installed on a safe place of any fluid (rain, moisture, etc.), dust and pests.
- You must route the various electrical cables through protective tubes, to protect them against mechanical exertions, essentially on

01. SAFETY INSTRUCTIONS

the power supply cable. Please note that all the cables must enter the control board from the bottom.

- If the automatism is to be installed at a height of more than 2,5m from the ground or other level of access, the minimum safety and health requirements for the use of work equipment workers at the work of Directive 2009/104/CE of European Parliament and of the Council of 16 September 2009.
- Attach the permanent label for the manual release as close as possible to the release mechanism.
- Disconnect means, such as a switch or circuit breaker on the electrical panel, must be provided on the product's fixed power supply leads in accordance with the installation rules.
- If the product to be installed requires power supply of 230Vac or 110Vac, ensure that connection is to an electrical panel with ground connection.
- The product is only powered by low voltage safety with control board (only at 24V motors).
- Parts/products weighing more than 20 kg must be handled with special care due to the risk of injury. It is recommended to use suitable auxiliary systems for moving or lifting heavy objects.
- Pay special attention to the danger of falling objects or uncontrolled movement of doors/gates during the installation or operation of this product.

WARNINGS FOR USERS

- Keep this manual in a safe place to be consulted whenever necessary.
- If the product has contact with fluids without being prepared, it must immediately disconnect from the power supply to avoid short circuits, and consult a specialized technician.
- Ensure that technician has provided you the product manual and informed you how to handle the product in an emergency.
- If the system requires any repair or modification, unlock the automatism, turn off the power and do not use it until all safety

conditions have been met.

- In the event of tripping of circuits breakers or fuse failure, locate the malfunction and solve it before resetting the circuit breaker or replacing the fuse. If the malfunction is not repairable by consult this manual, contact a technician.
- Keep the operation area of the motorized gate free while the gate in in motion, and do not create strength to the gate movement.
- Do not perform any operation on mechanical elements or hinges if the product is in motion.

RESPONSABILITY

- Supplier disclaims any liability if:
 - Product failure or deformation result from improper installation use or maintenance!
 - Safety norms are not followed in the installation, use and maintenance of the product.
 - Instructions in this manual are not followed.
 - Damaged is caused by unauthorized modifications
 - In these cases, the warranty is voided.

MOTORLINE ELECTROCELOS SA.

Travessa do Sobreiro, nº29
4755-474 Rio Côvo (Santa Eugénia)
Barcelos, Portugal

SYMBOLS LEGEND:



• Important safety notices



• Useful information



• Programming information



• Potentiometer information



• Connectors information



• Buttons information

02. AWNING

COFRE 600

The **COFRE 600** is a large, fully enclosed awning. It has articulated arms of double cable, more robust and strong to confer greater resistance and to allow a greater projection of the fabric. Optionally, the awning can be provided with an independent lighting kit, which can be applied in the area protected by the awning. Allows a maximum slope of 20 °.

On the awning you will find the following components:

- | | |
|-------------------------------------|-------------------------------------|
| 01• Cofre Cover | 14• Support pin |
| 02• Side plate | 15• Articulated arm |
| 03• Lower Protection Profile | 16• Terminal |
| 04• Lower Profile Support | 17• Front Profile |
| 05• Support arm assembly | 18• Plastic Protection |
| 06• Wall Support | 19• Front Profile Cover |
| 07• Holder Support | 20• Commands |
| 08• TUB90M8 MT Motor | 21• Crank |
| 09• Top profile | 22• Central MC65 |
| 10• Winding tube \varnothing 78mm | 23• Transformer |
| 11• Central Vault Profile | 24• Safety crank |
| 12• Square tube 50x50 | 25• Double Ceiling Mounting Bracket |
| 13• Tube socket | 26• Ceiling Mounting Bracket |



Both ceiling mount brackets are not included in the awning. They must be purchased separately.

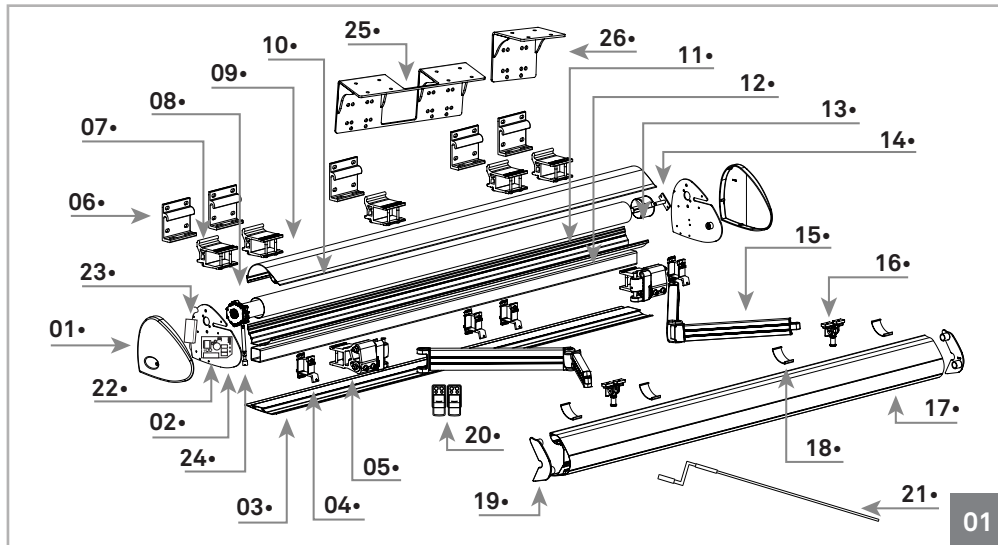

02. AWNING

TECHNICAL CHARACTERISTICS

The technical characteristics of the awning **COFRE 600** are as follows:

	Production measure	Motor used
Up until 5m	4,7 x 4,0	TUB 90M8 MT
	5,0 x 4,0	TUB 90M8 MT
Up until 6m	5,5 x 4,0	TUB 90M8 MT
	6,0 x 4,0	TUB 90M8 MT
Up until 7m	6,5 x 3,5	TUB 90M8 MT
	6,5 x 4,0	TUB 90M8 MT
	7,0 x 3,5	TUB 90M8 MT
	7,0 x 4,0	TUB 90M8 MT

Technical data of the Motor TUB 90M8 MT

• Power Supply	AC 230V 50Hz
• Power	227W
• Speed	12RPM
• Force	50Nm
• Lift up	<90Kgs
• Noise	<43dB
• Working time	4min
• Diameter	\varnothing 45mm
• Weight set	3,70Kgs

03. INSTALLATION

HOLDERS INSTALLATION MEASUREMENTS

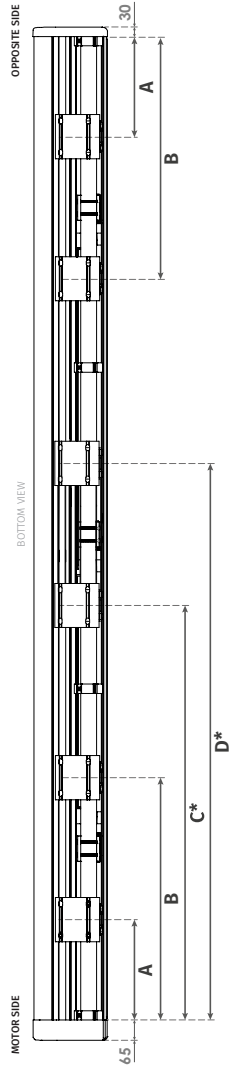

PROJECTION (mm)	WIDTH (mm)																					
	4700		5000		5500		6000		6500		7000											
3500	A	B	A	B	A	B	A	B	A	B	A	B	C	D								
4000	270	500	125	170	200	640	200	640	center	250	250	740	center	740	center	140	480	2375	2690	580	2225	2545

A distance from top to center of support 1 **C*** distance from top to center of support 3

B distance from top to center of support 2 **D*** distance from top to center of support 4

* This measurement must respect the orientation of the awning's 3rd arm support.
 Left, if the arm is applied to the left.
 Right, if the arm is applied to the right.

03. INSTALLATION

PRE-INSTALLATION

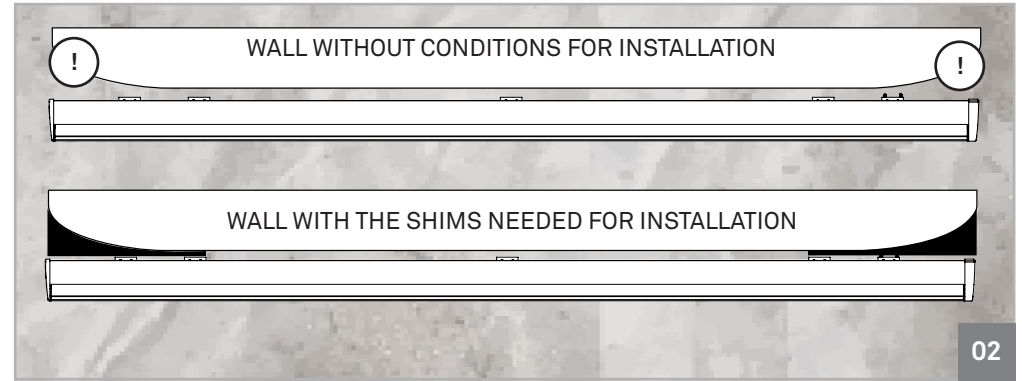

! Before starting the installation check the wall alignment. If it is not flat, you must create shims, so that the tightening points of the awning to the wall are perfectly aligned and level. You should also make sure that the metal bushings / screws are tightened onto a sturdy surface so there is no risk of loosening and dropping the awning. You should never open the safe without installation being complete as it may endanger your physical integrity. These points are very important because the safety and stability of the awning reside mainly in its fixing!

For correct functioning of the awning, it is mandatory to place the supports in the identified areas. Always place 1 support on each side of the armrest and divide the rest evenly. Never change the placement of the armrests!

Awning between 4200mm and 5500mm	Awning between 5501mm and 6500mm	Awning between 6501mm and 7000mm
4 supports	5 supports	6 supports

i The COFRE brackets are not in the correct installation location when shipped from the factory, proceed as shown in the following images.

03. INSTALLATION

FIXING ON THE WALL

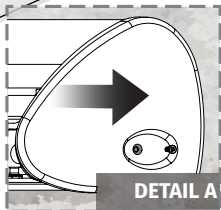
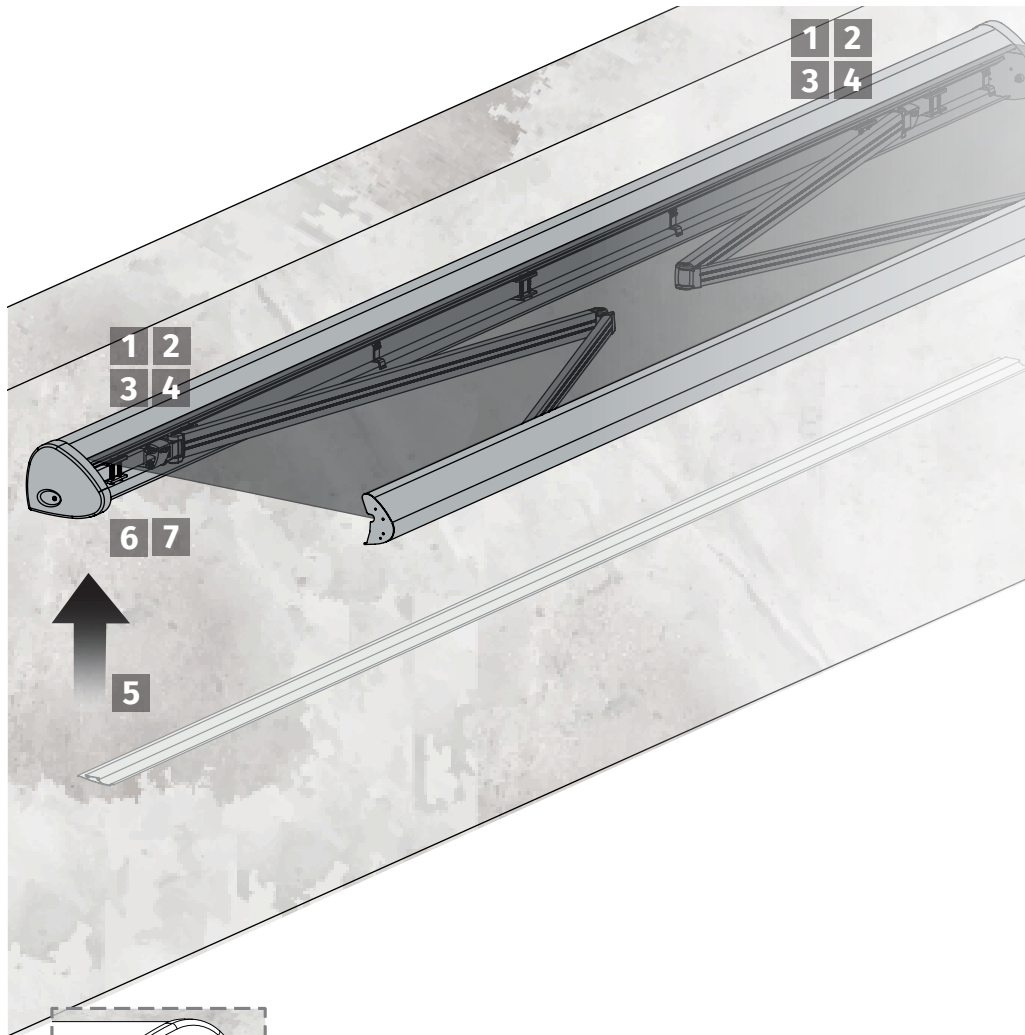

 The screws, bushings and washers are not included in the kit.

1 FIXING WALL SUPPORT
Identify the drilling points for the placement of the wall supports. Drill holes with **100mm** depth and **ø20mm**. Place the **M12** metal bushings in the holes created. Position the wall support in the holes and apply the **M12x90** screws with their washers.

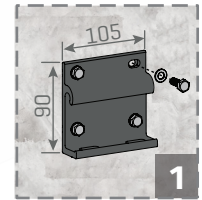

2 APPLY THE COFRE
Apply the holder support to the wall bracket.

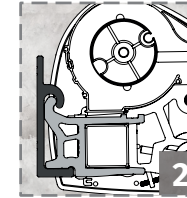
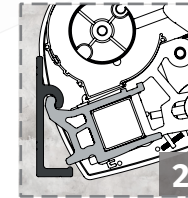
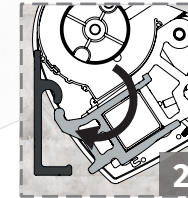

3 FIXING HOLDER SUPPORT
Attach the **ISO7380** screws (**M10 x 30**) with the washers to secure the supports.

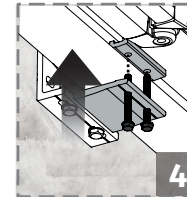
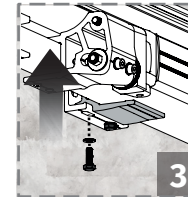

4 Apply **DIN933** screws (**M8x75**) with the washers and tighten until fully secured.

5 APPLY INFERIOR PROTECTION PROFILE
Remove the screw and the cover from one side (see detail A). Open the awning with the crank at 500mm and apply the inferior protection profile.

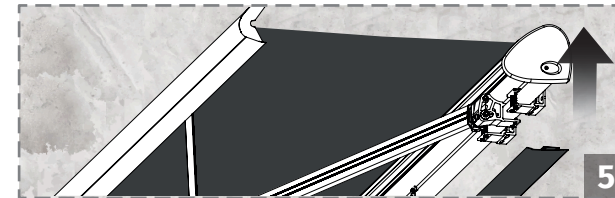

6 Attach the profile into the slot. Raise the profile until it is possible to tighten the screw.

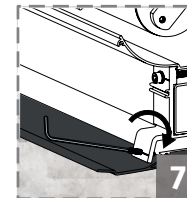
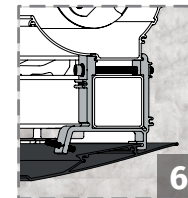

7 Finally, replace the cover on the sides of the cofre with the screws.

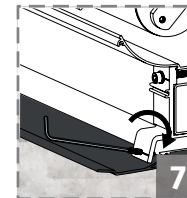
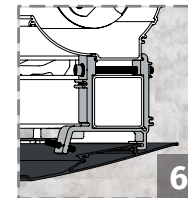

03. INSTALLATION

FIXING ON THE CEILING

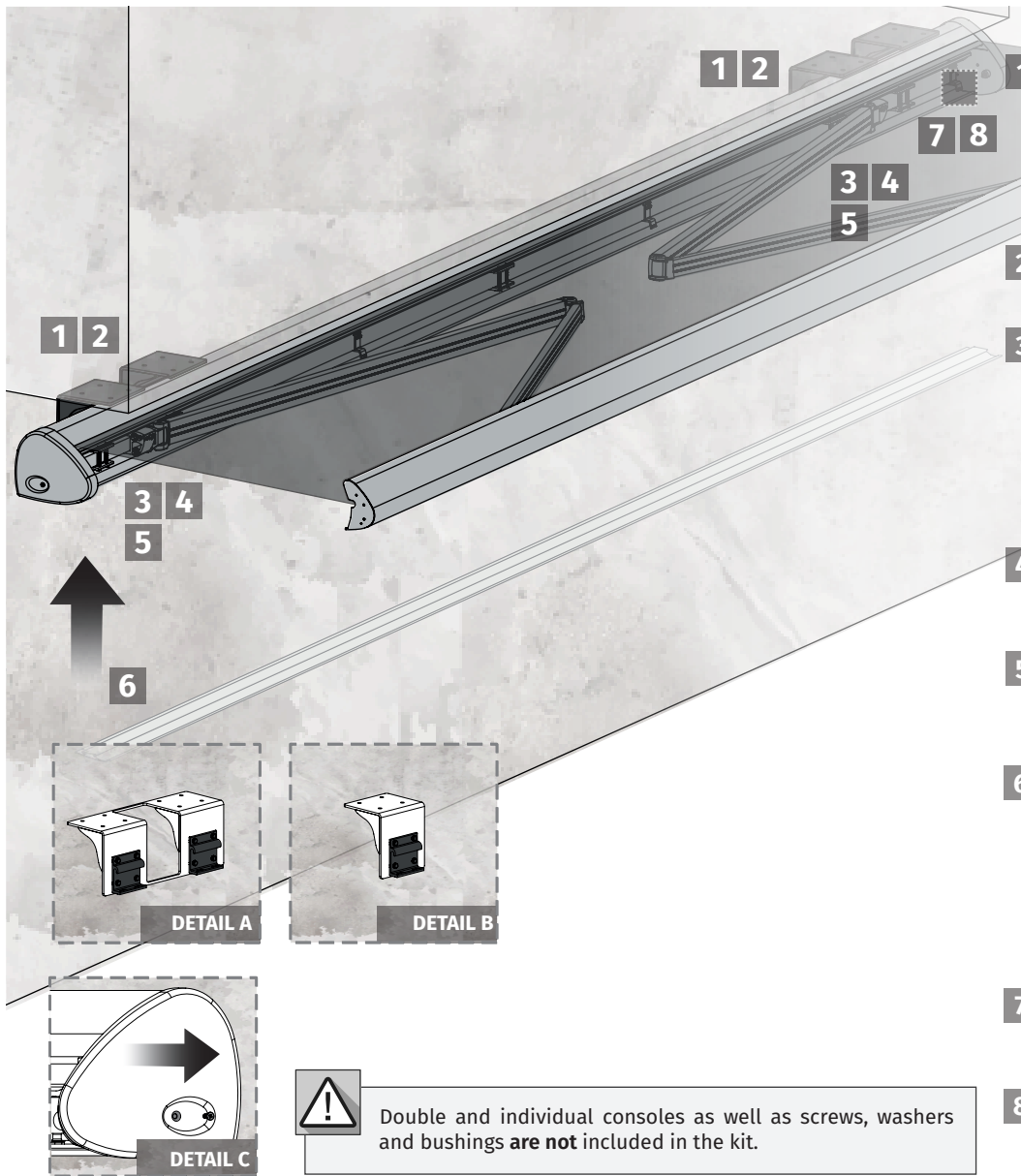

1 FIXING HOLDER SUPPORT

Fasten to double consoles using M12 bolts with washers (another option see detail A).



If the Awning is between 5501mm and 6500mm, place an individual console centered with the holder.

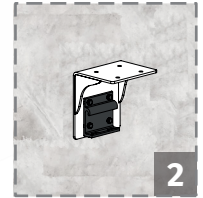
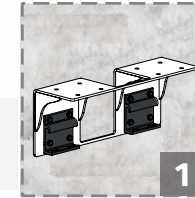

2 Fasten to individual console using M12 bolts with washers (another option see detail B).

3 APPLY THE COFRE
Apply the holder support to the wall bracket.

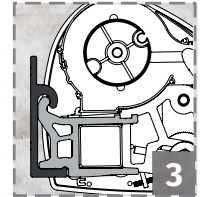
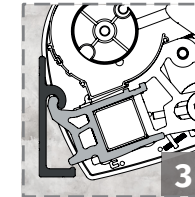
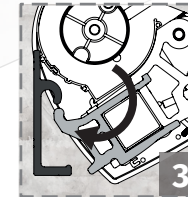

4 FIXING HOLDER SUPPORT
Attach the ISO7380 screws (M10 x 30) with the washers to secure the supports.

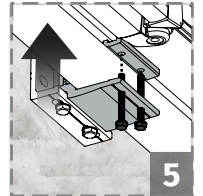
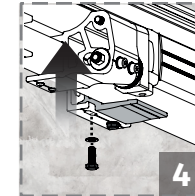

5 Apply DIN933 screws (M8x75) with the washers and tighten until fully secured.

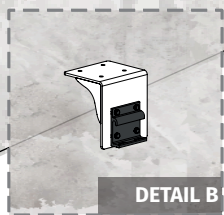
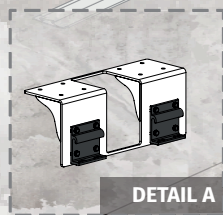

6 APPLY INFERIOR PROTECTION PROFILE
Remove the screw and the cover from one side (see detail C).
Open the awning with the crank at 500mm and apply the inferior protection profile.

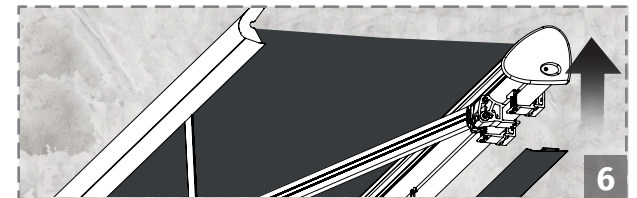

7 Attach the profile into the slot.
Raise the profile until it is possible to tighten the screw.

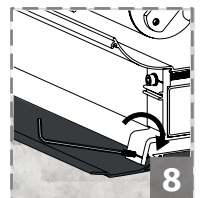
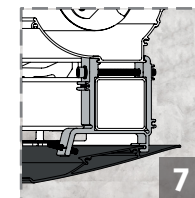

8 Finally, replace the cover on the sides of the cofre with the screws.



Double and individual consoles as well as screws, washers and bushings are **not** included in the kit.

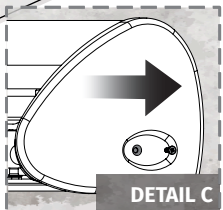

04.REGULATION

SETTING THE ARM JOINT

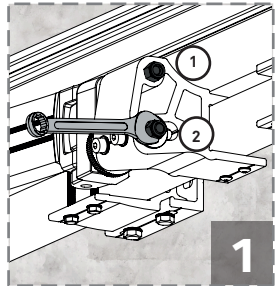
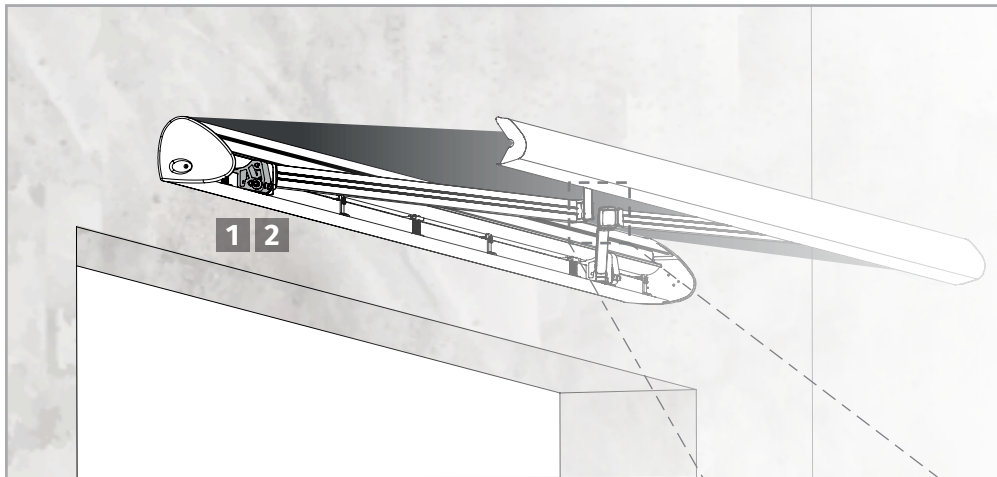

1 LOOSEN SCREWS

With the awning open at about 500mm, loosen screws 1 and 2 slightly.

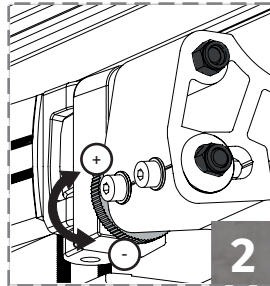

2 AFFECT THE ARTICULATION

To raise or lower the joint, rotate the wheel in one direction or the other.

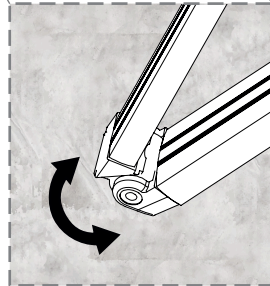

While performing the operations, the joint will initiate the changes of ascent or descent.

04.REGULATION

ADJUSTING THE AWNING TILT

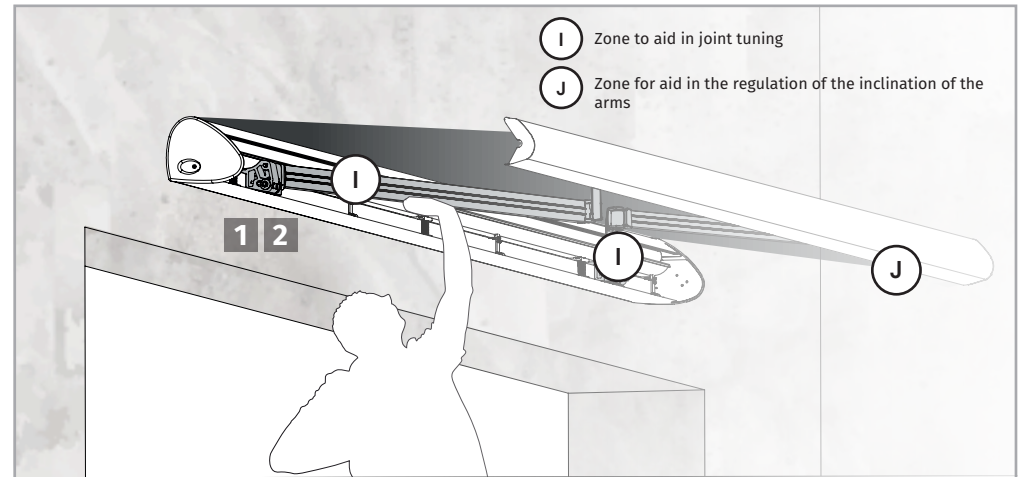

1 REGULAR AWNING

To start adjusting the slope of the Awning, place it fully open. You should assist the arms with the hand throughout the process.

- 2 Unlock the screw 3 and loosen the screws 4 alternately until you find the desired incline. Turning to the right the arm goes up, turning to the left the arm descends. Do this operation in one arm and then in the other. **Do not unscrew both arms at the same time.**

Retighten screw 3 when you are satisfied with the slope of the Awning.

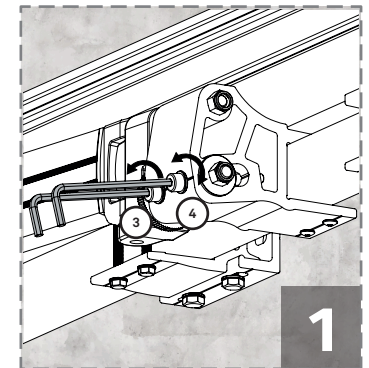

04.REGULATION

ADJUSTING FRONT PROFILE

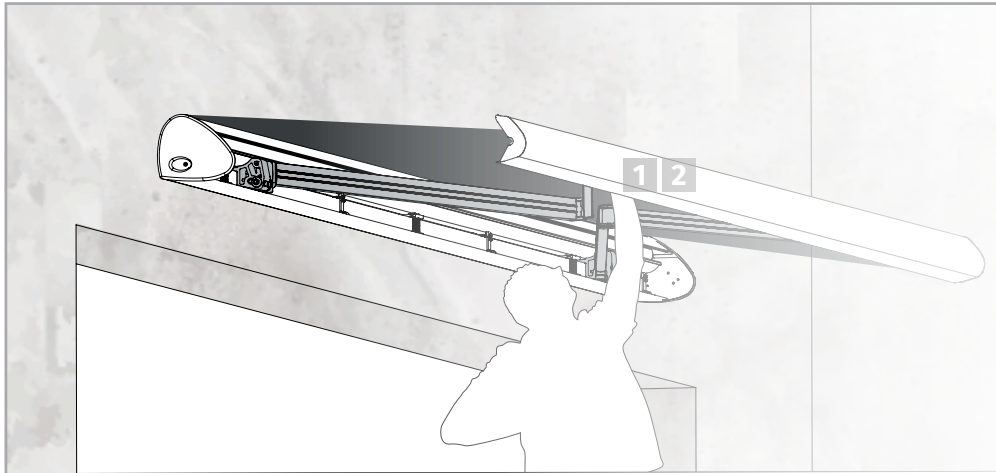

The Awning is already out of the factory tuned. This adjustment is only necessary when the arm inclination is changed.

1 REGULATE FRONT PROFILE

In order to optimize the closing of the awning, it is necessary to adjust the inclination of the front profile according to the inclination of the arm. Place the awning open at about 500mm.

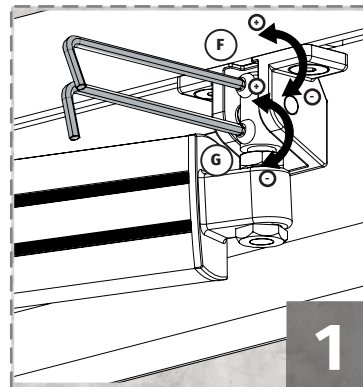

- 2 Tighten or unscrew the screws (F, G) until the desired setting is found.



Never loosen the screws in their entirety!

Improper front profile adjustment can cause damage when closing the awning! Too low or too high positioning of the hinge can cause tarpaulin or top deterioration whenever the awning is closed!

04.REGULATION

MANUAL UNLOCKING

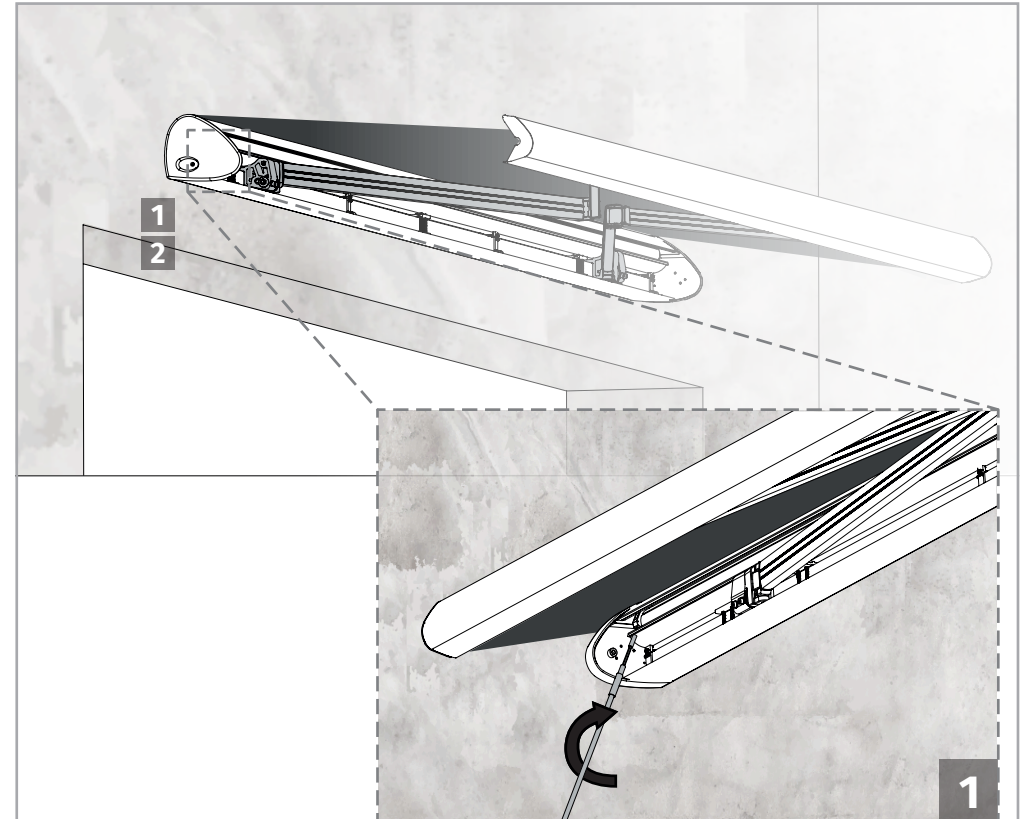

1 UNLOCKING AWNING

The awning is arranged so that, in case of power failure or other situation that prevents the electrical operation of the equipment, it is possible to open or close the awning manually by means of the crank.

- 2 Put the crank and turn it to open / close the awning.

04.REGULATION

ENDS OF COURSE



1 UNLOCK THE SCREWS
Unscrew the screws and remove the covers on the left and right side.

2 Fully loosen the 4 screws that secure the upper profile to the two covers.

3 REMOVE THE PROFILE
Remove the top profile from the cover.

4 START THE ENGINE
The tuning can be performed according to the image below.
At the end, reinstall the profile and cover to close the awning.

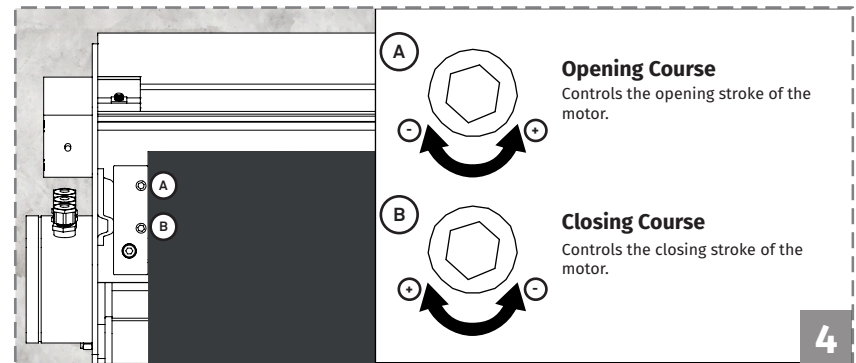
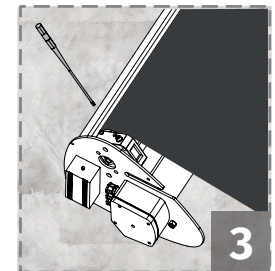
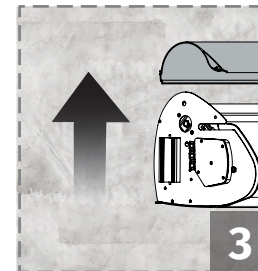
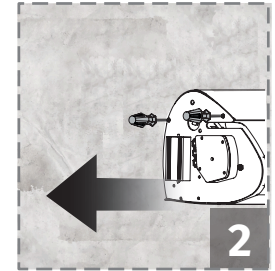
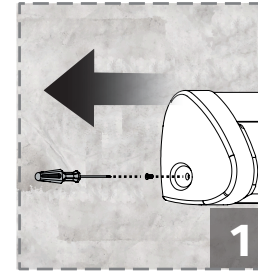

05. TROUBLESHOOTING

FINAL CONSUMERS AND SPECIALIZED TECHNICIANS INSTRUCTIONS

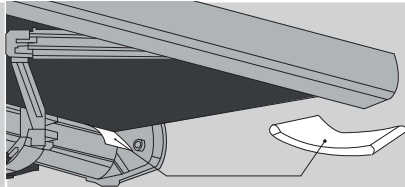
Problems	Behavior	Procedure
The awning is not secure properly on the wall.	<ul style="list-style-type: none"> The screws are not suitable for the wall structure. 	<ul style="list-style-type: none"> Check the installation measures. Check that the number of screws is sufficient and that they are indicated in this manual.
The awning does not remain level after opening.	<ul style="list-style-type: none"> Changes to the tarpaulin after several maneuvers. Incorrect adjustment of the top or articulated arms. 	<ul style="list-style-type: none"> Check the level of the wall brackets. Check the level of the square tube. Correct the inclination of the arms taking into account the instructions in the manual.
The top does not close in full.	<ul style="list-style-type: none"> Defacing the top or limit switch. 	<ul style="list-style-type: none"> Adjust the arms. Adjust the top slope. Tune the motor limit switches.
The top does not close on one side.	<ul style="list-style-type: none"> Natural screen extension. 	 <ul style="list-style-type: none"> Open the awning. Place a folded plastic can in 4, on the side where the screen changes, between the tube and the screen. If necessary add more shims until the screen is normal. If the latch still does not fit, fold the plastic latch further to gain thickness and redo the same operations.
The awning does not work and the motor makes no noise.	<ul style="list-style-type: none"> The motor enters thermal protection after 2 openings and 1 lock. 	<ul style="list-style-type: none"> Wait 20 minutes.
The awning does not work and the motor makes no noise.	<ul style="list-style-type: none"> Protection problem. 	<ul style="list-style-type: none"> Check the motor connection. Check engine operation by connecting directly to mains.